



World Class Gasket Manufacturer

NORTH AMERICA & CANADA

IMPERIAL SYSTEM

the legacy in sealing technology



Content

Leader Gasket: World Class Gasket Manufacturer	4
Semi-Metallic gaskets	13
Leader Spiral Wound gaskets	14
LeaderKAM kammprofile gaskets	16
Leader Elastagraph™	18
Leader Elastagraph™-SG	20
Sheet Material gaskets	22
Leader Clipperlon 2100	23
Leader Clipperlon 2110	24
Leader Clipperlon 2115	25
Leader Clipperlon 2120	26
Leader Clipperlon 2130	27
Leader Clipperlon 2135	28
Leader Clipperlon 600	29
Leader Clipperlon 660	30
OEM industries	31
LeaderTHERM	33
HPL Flexible Graphites	34
Tables	35
Chemical resistance guide	44
Profile overview	50
Metal Jacketed Gaskets	50
Fixed Equipment Shapes	51
Find your local LEADER	56





LEADER GASKET:

World Class Gasket Manufacturer

Leader Gasket is a manufacturer of metallic, semi-metallic and soft gasket products. Originally founded in 1989 in Baton Rouge - Louisiana, focused on Spiral Wound technology and Specialty Equipment gaskets such as Corrugated Metal gaskets, Leader has evolved into a global manufacturer of gaskets and gasket products for various industries using the latest technologies.

Leading the industry

Today, we are the leading global provider for numerous industries, ranging from petrochemical multinationals and the automotive industry to small and medium enterprises all over the world. From our offices in Deer Park - Texas, Baton Rouge - Louisiana and Bytča - Slovakia we offer gasket solutions for every business, from mass production of standards to very specific custom-made.

Innovations

Our innovations include the patented Elastagraph technology, reducing emissions in the environment, API RTJ Rings, Leader Spiral Wound gaskets meeting the highest specs set out by the Petrochemical Industry, Kammprofiles for both pipe flanges and equipment installations and a full range of soft sheet materials. Additionally, we manufacture an array of semi metallic specialty gaskets for our OEM customers. The most recent addition was our internally manufactured Biax Process (filled and Biaxially oriented PTFE) marketed under our Clipperlon brand.

Sustainable Gasket Solutions

There are many parameters which impact the performance of a gasket. Identifying these factors and ensuring they are all optimized to provide you with a safe and sustainable flange connection is at the core of our business. This includes advanced gasket selection tools, training on-site and flange management programs for maintenance, such as Total Flange Care and Flange Integrity Management.

Technical Testing

Leader has its own in-house testing capabilities that meets the current industry standards. This allows Leader to test gaskets according to the current state of technology in accordance with industry standards (for example, standard leakage tests or pressure strength, relaxation and crushing tests) and also to distribute the required characteristic values in accordance with EN 13555. In addition to the above-mentioned tests, the sealing behaviour, as required in the VDI 2440/2200, can be determined according to previous Temperature storage.

Engineering Solutions

Leader Gasket engineers and product specialists have the know-how to provide recommendations and solutions for all your gasket needs. The engineered staff is both in-house and field rep. experienced in close cooperation all partners.

Investing in the Future

Leader Gasket invests in a sustainable future by developing new types of flange connections which further reduce emissions and increase safety. Our engineering team uses its own state of the art AMTEC test equipment, FEA analytical programs and 3d drawing programs to test and develop these new designs.



Capabilities



Engineering Team

The Leader Gasket engineers and product specialists cooperate intensively with maintenance specialists and mechanical engineers in the industry.

Our market know-how allows us to develop new customized solutions and techniques creating cost savings for our customers. Our Leader Gasket team is ready to provide technical expertise and support to solve existing or potential problems. We participate on project preparation and finalize complete gasket solutions.

Our special team of skilled and experienced experts provide assistance on the selection and use of Leader Gasket products being equipped with a modern laboratory.

Our engineering teams in both US and Europe are available for your request even on daily live chat via www.leadergt.com

OUR ENGINEERS ARE QUALIFIED TO HELP YOU WITH:

- Emission reduction programs
- Installation procedures
- Material & design selection
- Bolt load calculation & recommendations
EN1591-1/ASME Boiler & Vessel Code Calculations
- Bolting procedures
- Flange machining recommendations
- On-site training (Flange Integrity Management)
- Product R&D and in-house testing
- Review of corporate piping standards to implement product consolidation to reduce inventory cost
- Co-engineering of customized parts and gasket solutions
- Safety consulting and procedures

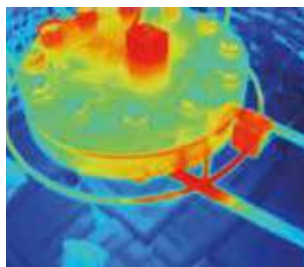
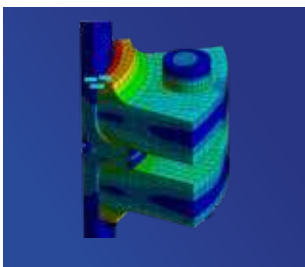

Quality

Product quality and reliability are the fundamental elements for our success as a trusted manufacturer in the industry. We go above and beyond industry standards to ensure that our products are manufactured with high quality, high performance materials and consistent, repeatable and documented procedures. All special alloys are 100% PMI tested and documented to ensure products are supplied as specified. Detailed material test reports, PMI travelers, independent testing results and other quality documentation can be provided upon request.



Materials for Manufacturing

Leader Gasket carries a plethora of raw materials from standard 304 and 316L materials to Titanium, Alloy 20, Monel, Hasteloy, and other exotics. Our material specifications, on-site vendor and incoming goods inspections assure our end customers receive only the highest quality materials on each and every order.



Testing and Development Laboratory

- AMTEC testing equipment
- Emission reduction tests and development
- Product/Production innovation
- Testing according to International Standards
- DIN 28090, EN 13555 or ASTM
- Customer specific tests and projects
- Bolting and torque calculations according EN 1591



Turnaround Support

Leader Gasket offers complete support for turnarounds, plant shutdowns, and production stops for industrial companies. This involves the replacement of gaskets for chemical plants, oil refineries, power generation companies and other industrial sectors. Whether it is for emergency repairs or planned shutdowns, Leader has the management and staff in-house to carry out these stops including all logistic services needed such as on site container services. Together with its allied distributor partners Leader can offer a full service concept of supply; service and on site support.



Traceability

Traceability is the ability to verify the history, location, or application of an item by means of documented recorded identification. Material traceability is important to the aerospace, nuclear, and process industry because they frequently make use of high strength materials that look identical to commercial low strength versions.

Leader Gasket guarantees full traceability using a heat code, job number and batch code on all manufactured products. This allows easy identification of raw materials and production settings. In case of special customer request we can provide customized product traceability, documentation and certification.

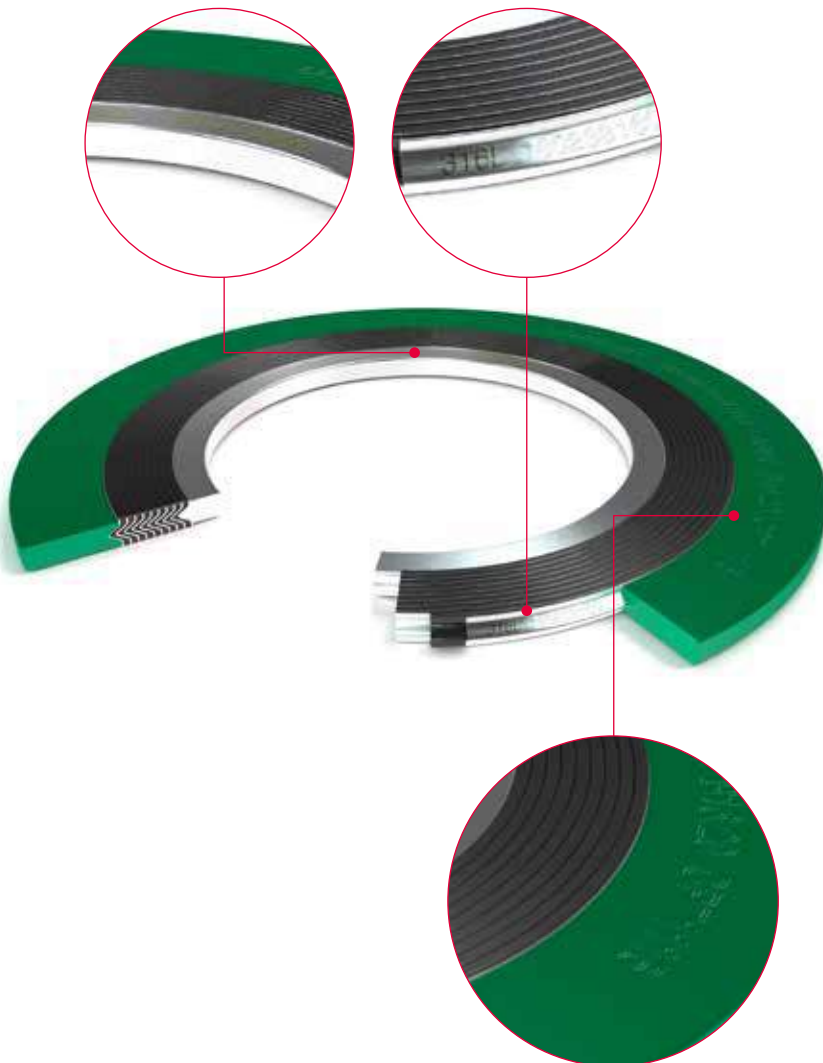

ALL METAL MATERIAL PARTS AND FILLER MATERIALS OF THE STANDARD SRI SPIRAL WOUND CONSTRUCTION ARE TRACEABLE

The Spiral Wound Gasket is considered to be one of the safest and most reliable of its kind but is still often seen as a commodity. Nevertheless it is a complex product containing a configuration of Windings, Fillers, Inner and Outer rings that are wound, welded and fitted together. This is how we keep control and you can sleep tight:

- Highly detailed manufacturing specification requirements are in place to insure standardization, performance, and quality of each spiral wound gasket.
- High performance (low emissions) graphite filler is controlled with a detailed product specification and through the use of specialized TGA testing requirements for each lot of graphite material used. In process inspections by qualified inspectors in accordance with ASME B16.20 standards are performed and documented on every shipment.
- Leader Gasket in-house quick supply special gaskets are manufactured to the same stringent specification requirements.
- Traceability is achieved through detailed MTR (material test reports and certificates) documentation for inner/outer rings, metal windings, and graphite filler.
- All metal material parts and filler materials of the standard SRI Spiral Wound construction are traceable for each gasket by use of a unique traceable number (batchcode) marked on the inner/outer guide rings along with the etching of the metal winding material.
- Standard 304 & 316ss SR/SRI guide rings are painted on the face with the matching ASME color code (Green for 316 & Yellow for 304ss) for a quick visual reference when stocking.

Total Flange Care

There are many parameters which impact the performance of a gasket. Identifying these factors and ensuring they are all optimized to provide you with a safe and sustainable flange connection is at the core of our business. At Leader Gasket we call this approach Total Flange Care.

Innovation

The development of gaskets is a process that is always in motion. At Leader Gasket we operate in the forefront of this field. Our engineering team utilizes the latest techniques to develop innovative gaskets, specifically designed to perform optimally in increasingly complicated processes in various industries.

Gasket Failure?

A leaking flange connection is often called a "gasket failure". Yet, in many cases simply replacing the gasket doesn't solve the problem. This is because there are many factors which have a direct and indirect impact on the performance of a flange connection. The gasket itself is a very important part of the equation, but it can only perform as intended when it is properly installed and maintained.

Flange Integrity Management

This why we call a leaking flange connection an "integrity problem". Our approach to solving this problem is Flange Integrity Management. This is where we systematically identify all the contributing factors that cause the leak and establish the right approach to come up with a lasting solution.

Four Parameters

Safety and sustainability are the highest concern with industrial gaskets. Creating and maintaining a leak free flange connections is of the utmost importance. At Leader Gasket Technology we always look at the combination of the following four parameters:

- Gasket
- Flanges and bolts
- Assembly
- Operating conditions

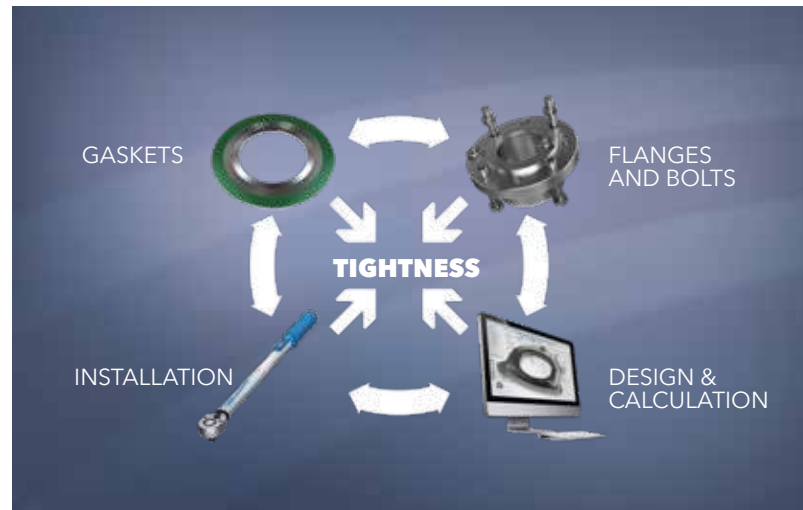

MEETING THE HIGHEST STANDARD!

- ↳ Training mechanics / engineers EN1591-4
- ↳ Advising gasket selection
- ↳ Inspection and recommendation flange parameters
- ↳ Gasket testing
- ↳ Calculation bolt force, tightness and emission
- ↳ Flange management programs
- ↳ LDAR

Sustainable Gasket Solutions



Leaks can cause the emission of gases and vapors in pressurized industrial equipment. Losing raw materials is not only problematic because of costs. This loss also creates a multitude of risks and dangers. In the long term, certain chemicals may pose a risk to the health of workers. A leak of flammable substances increases the risk of fire and explosion. In addition, the emission of chemical substances is harmful to the environment.

Emission reduction

Gaskets and pipe connections are the greatest risk to potential leakage points and emission. In large industrial installations there are many gaskets present and when these gaskets are not reliable, total emission can soar. Leader Gasket is specialized in gaskets that reduce fugitive emissions. Through education about the proper gasket selection, proper calculations and installation advice, Leader can help any industry with emission reduction.

LEAKING IS DANGEROUS AND COSTLY!

- Unsafe situations
- Emission
- Environmental impact
- Loss of production
- Loss of product
- Cleaning cost
- Extra maintenance

QUALITY & SAFETY STATEMENT

Quality, Safety and Sustainability are of high concern for Leader Gasket; both towards our associates, customers and communities we live in. Within the company and towards the market a clear vision on Quality and Safety has been integrated including principles. Health, safety and environmental commitments are described and implemented throughout the organization. Special teams are in place to consciously strive for improvement committed by the management. 6 Golden Rules of Safety are implemented throughout the entire organization.

Industries



Chemicals



OEM industries



Energy



Oil & Gas



Food & Pharmaceuticals



Primary industries



Fuel cell industries



Refineries



Maritime sector

Certificates & Tests



Summary of the tests and certificates for Leader Gasket products.

Spiral Wound Gaskets -SRI

- TA-Luft
- EN13555
- BAM
- Hot Blow Out test
- Fire Safe API 6FB

Kammprofiles

- TA-Luft
- EN13555
- BAM
- Fire Safe API 6FB

Elastagraph Gaskets

- TA-Luft
- EN13555
- BAM
- Hot Blow Out test
- Fire Safe API 6FB
- DVGW

Elastagraph Gaskets with inner eyelet

- TA-Luft

Corrugated Gaskets CG

- EN13555

Filled PTFE - Clipperlon 2100, 2110, 2120, 2130

- TA-Luft
- Blow Out test
- FDA
- EC1935/EU10/2011

For a copy of the original and accurate certificate we refer to our website: www.leadergt.com

Determining the characteristic values of gasket

- Characteristic values according to EN 13555
- Qsmax and Qsmin (EN 13555)
- PQR value (EN 13555)
- EG module (EN 13555)
- DIN 28090, DIN 28091
- DIN 3535
- DIN 52913
- TA-Luft VD2440



SEMI - METALLIC GASKETS

Leader Spiral Wound Gaskets

HIGH INTEGRITY SWG GASKETS

The spiral wound gasket (SWG) is without a doubt one of the most widely used semi-metallic gaskets. The design is based on an existing concept which has proven its excellent properties over many years.

The basic principle of the spiral wound gasket consists of alternating layers of V-shaped metal coils and soft, non-metallic filling material. The first and the last coils consist only of metal in order to reinforce the spiral on the inner and outer diameters.

This "alternating plies" construction, in conjunction with the special V-shape of the spiral metal band and the properties of the filling material make the spiral wound gasket ideal for applications with high temperatures and associated voltage differences, joint relaxation and flange twists.

Applications

- Piping (DIN/ANSI)
- In the event of Temperature fluctuations
- Tongue and groove connections
- Heat exchangers
- Equipment
- Steam boilers
- High pressures

MIN/MAX PIPE FLANGE GASKET STRESS LIMITS			
STYLE	Y VALUE PSI	Optimal PSI	max. PSI
S&SR			
Graphite filler	10,000	12,500 to 25,000	35,000
SI/SRI			
Graphite filler	10,000	12,500 to 25,000	40,000
S&SR			
ePTFE filler	10,000	12,000 to 25,000	35,000
SI/SRI			
ePTFE filler	10,000	12,000 to 25,000	40,000

Latest version of productdatasheet available on www.leadergt.com

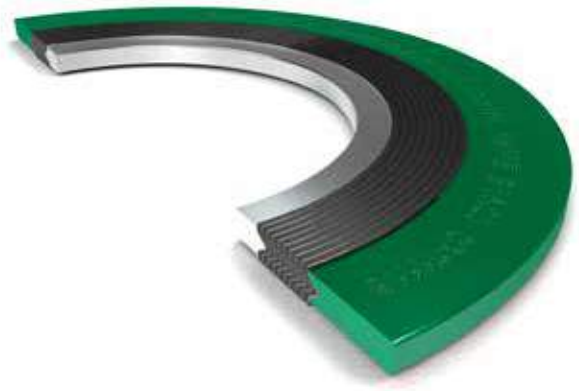

Properties

Outer ring

- Centering of the gasket
- Prevents blow-out
- Increase in mechanical strength
- Marking information
- Material: steel, stainless steel, non-ferrous metals

Inner ring

- Prevention of turbulence
- Helps prevent inner buckling
- Protection against gasket entering process media
- Required for PTFE filled gaskets
- Required for vacuum service

Spirals

- .125", .175", .250", .285" standard thicknesses
- Filler: Graphite, ePTFE, LeaderTherm
- Metal band: in various grades
- Actual sealing function

Pressure

- Max. Per ASME B16.5 flange ratings or depending on the installation and surface pressure for equipment flanges

Approvals



STYLES OF LEADER SPIRAL WOUND GASKETS

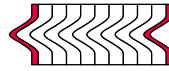
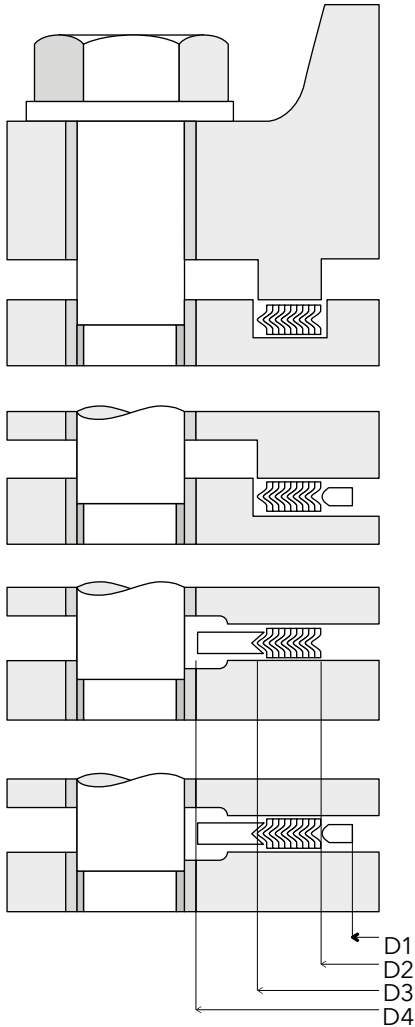

Style S without inner and outer ring

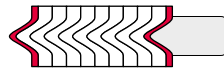

Style SI with inner ring



Style SR with outer ring



Style SRI with inner and outer ring



NON-METALLIC FILLERS - ASME B16.20						
Material	Minimum		Maximum		Abbreviation	Guide Ring Color Code
	°F	°C	°F	°C		
Flexible Graphite	-350	-212	975	510	F.G.	Gray
PTFE	-400	-240	500	260	PTFE	White
Leadertherm	-350	-212	1800	677	LT	Light Blue
Leadertherm/Graphite	-350	-212	1500	816	LTD	Light Blue/ Gray

COLOR CODE CHART - ASME B16.20						
Material	Minimum		Maximum		Abbreviation	Guide Ring Color Code
	°F	°C	°F	°C		
304 Stainless Steel	-320	-195	1400	760	304	Yellow
316L Stainless Steel	-328	-200	1600	870	316L	Green
317L Stainless Steel	-150	-100	1600	870	317L	Maroon
321 Stainless Steel	-320	-195	1600	870	321	Turquoise
347 Stainless Steel	-320	-195	1600	870	347	Blue
Carbon Steel	-40	-40	1000	540	CRS	Silver
20Cb-3 (Alloy 20)	-300	-185	1400	760	A-20	Black
HASTELLOY® B 2	-300	-185	2000	1090	HAST B	Brown
HASTELLOY® C 276	-300	-185	2000	1090	HAST C	Beige
INCOLOY® 800	-150	-100	1600	870	IN 800	White
INCONEL® 600	-150	-100	2000	1090	INC 600	Gold
INCONEL® X750	-328	-200	1500	820	INX	No Color
MONEL® 400	-200	-130	1500	820	MON	Orange
Nickel 200	-320	-195	1400	760	NI	Red
Titanium	-320	-195	2000	1090	TI	Purple

Temperatures are for guideline only

Other materials available on request
 * the information listed here is not claimed to be exhaustive and serves only as a guide; despite careful content control we assume no liability or guarantee for the topicality, correctness and completeness of the information provided
 ** (to 1000 °F only after consultation)

LeaderKAM

KAMMPROFILE GASKETS

The use of kammprofile gaskets has increased enormously in recent decades - not only for the sealing of standard flanges, but also for equipment components, such as heat exchangers and containers.

LeaderKAM kammprofile gaskets with soft material layers are characterized on the one hand by a very low minimum surface pressure which is determined by the facing material type. On the other hand, the maximum permissible surface pressure is very high as this is determined by the material grade of the metal carrier material.

This gives the grooved gaskets with layers a very wide range of application. They are therefore almost universally applicable. The bolt force to be applied when using grooved gaskets is determined by the characteristic data of the fasteners and operating pressure/temperature.

Applications

- Flanged pipes (DIN/ANSI)
- Grooved flanges
- Heat exchanger
- Equipment
- Boilers
- High pressure



Properties

Metal Core

- Thickness: 1/16" thru 3/8"
- Stainless steel/steel in various high alloys
- Depending on the thickness of the layers, the carrier material contains the precisely machined serrated groove geometry and thickness

Soft material layer

- Thickness: .020" or .030"
- Inhibited grade graphite -400 to 850 F
- Super inhibited grade graphite -400 to 975 F
- ePTFE -450 to 500 F
- LeaderTherm 0 to 1800 F

Pressure

- Max. per ASME B16.5 pressure ratings or depending on the installation and surface pressure for equipment flanges.

Types (forms)

- Round, oval, rectangular
- With seam gaps according to drawing

Approvals



MIN/MAX PIPE FLANGE GASKET STRESS LIMITS			
STYLE	Y VALUE PSI	Optimal PSI	max. PSI
F, FR, FL LeaderKam			
Graphite Facing	2900	8,000 to 25,000	40,000 (consult with engineering for higher value)
ePTFE Facing	2900	8,000 to 25,000	40,000

Latest version of productdatasheet available on www.leadergt.com

STYLES OF LEADERKAM KAMMPROFILE GASKET

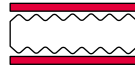
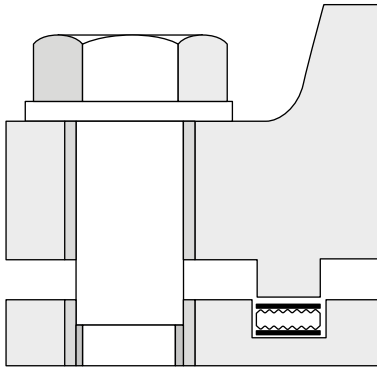

Style F without outer guide ring

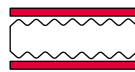
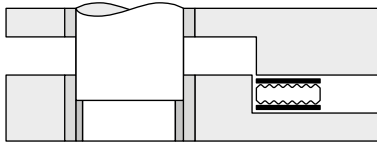

Style F without outer guide ring

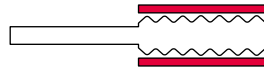
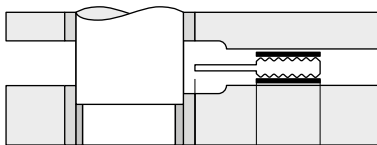

Style FR with fixed outer guide ring

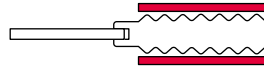

Style FL with loose outer guide ring

D1
D2
D3

NON-METALLIC FILLERS - ASME B16.20						
Material	Minimum		Maximum		Abbreviation	Guide Ring Color Code
	°F	°C	°F	°C		
Flexible Graphite	-350	-212	975	510	F.G.	Gray
PTFE	-400	-240	500	260	PTFE	White
Leadertherm	-350	-212	1800	677	LT	Light Blue
Leadertherm/Graphite	-350	-212	1500	816	LTD	Light Blue/ Gray

COLOR CODE CHART - ASME B16.20						
Material	Minimum		Maximum		Abbreviation	Guide Ring Color Code
	°F	°C	°F	°C		
304 Stainless Steel	-320	-195	1400	760	304	Yellow
316L Stainless Steel	-328	-200	1600	870	316L	Green
317L Stainless Steel	-150	-100	1600	870	317L	Maroon
321 Stainless Steel	-320	-195	1600	870	321	Turquoise
347 Stainless Steel	-320	-195	1600	870	347	Blue
Carbon Steel	-40	-40	1000	540	CRS	Silver
20Cb-3 (Alloy 20)	-300	-185	1400	760	A-20	Black
HASTELLOY® B 2	-300	-185	2000	1090	HAST B	Brown
HASTELLOY® C 276	-300	-185	2000	1090	HAST C	Beige
INCOLOY® 800	-150	-100	1600	870	IN 800	White
INCONEL® 600	-150	-100	2000	1090	INC 600	Gold
INCONEL® X750	-328	-200	1500	820	INX	No Color
MONEL® 400	-200	-130	1500	820	MON	Orange
Nickel 200	-320	-195	1400	760	NI	Red
Titanium	-320	-195	2000	1090	TI	Purple

* the information listed here is not claimed to be exhaustive and serves only as a guide; despite careful content control we assume no liability or guarantee for the topicality, correctness and completeness of the information provided
** (to 1000 °F only after consultation)

Temperatures are for guideline only

Leader Elastagraph™

EMISSION REDUCTION GASKETS

Elastagraph™ gaskets feature a corrugated core made of stainless steel in the carrier assembly, which is seamlessly molded with flexible graphite of different densities and thicknesses. This version provides much better sealing characteristics in comparison to standard corrugated metal gaskets.

Elastagraph's™ corrugated form ensures a constant springback against the flange surfaces. The reduced effective seal area achieved, benefits the bolt force when initial torque is applied, as the entire surface area is not immediately compressed.

In contrast to conventional graphite gaskets, the production method of the Elastagraph™ creates a type of seal without an open seam. The corrugated core is completely covered with graphite. An additional graphite area with a lower density is molded into the internal part of Elastagraph™ on both sides. This creates a low stress ring which significantly increases the sealing behavior in comparison to classical gaskets. The corrugated core is also made of stainless steel and can withstand high compressive loads.

Applications

- Flanged Pipes (DIN/ANSI)
- TA-Luft
- Vompensates for flange irregularities
- Emission reduction

Approvals



Properties

Metal Core

- Thickness: .024" nominal before corrugations
- Standard 1.4404 (316L ss)
- Other materials possible

Soft material layer

- Thickness: .020" or .030" typical
- Inhibited grade graphite: (-400 to 850 F)

Pressure

- Rated for ASME B16.5 class 150, 300, and 600 standard flanges

Types

- Round
- Only for standard flanges IBC or RF
- Standard dimension up to DN 600 or 24" NPS
- Special dimension as Elastagraph™ SG

Special Features

- High compressibility
- Good sealing behavior at low bolt forces
- Good flexibility in uneven flange surfaces
- Good sealability even on pitted surfaces
- High installation tolerance in assembly
- Very good springback function
- Good mechanical properties with Temperature fluctuations
- Very good stability (PQR)

Total thickness

- Standard: 1/16" or 1/8"

STYLE OF LEADER ELASTAGRAPH™ GASKET

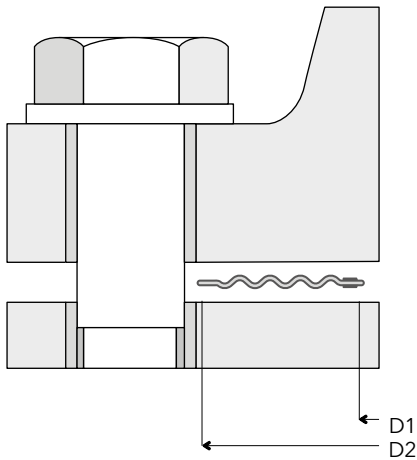

COLOR CODE CHART - ASME B16.20						
Material	Minimum		Maximum		Abbreviation	Guide Ring Color Code
	°F	°C	°F	°C		
304 Stainless Steel	-320	-195	1400	760	304	Yellow
316L Stainless Steel	-328	-200	1600	870	316L	Green
317L Stainless Steel	-150	-100	1600	870	317L	Maroon
321 Stainless Steel	-320	-195	1600	870	321	Turquoise
347 Stainless Steel	-320	-195	1600	870	347	Blue
Carbon Steel	-40	-40	1000	540	CRS	Silver
20Cb-3 (Alloy 20)	-300	-185	1400	760	A-20	Black
HASTELLOY® B 2	-300	-185	2000	1090	HAST B	Brown
HASTELLOY® C 276	-300	-185	2000	1090	HAST C	Beige
INCOLOY® 800	-150	-100	1600	870	IN 800	White
INCONEL® 600	-150	-100	2000	1090	INC 600	Gold
INCONEL® X750	-328	-200	1500	820	INX	No Color
MONEL® 400	-200	-130	1500	820	MON	Orange
Nickel 200	-320	-195	1400	760	NI	Red
Titanium	-320	-195	2000	1090	TI	Purple

Temperatures are for guideline only

Other materials available on request

* the information listed here is not claimed to be exhaustive and serves only as a guide; despite careful content control we assume no liability or guarantee for the topicality, correctness and completeness of the information provided

** (to 1000 °F only after consultation)

Note: All Elastagraph gaskets are painted yellow around the entire circumference to provide visibility of the actual color strip per the above chart due to the dark appearance of graphite. Exception: 304ss core will be solid yellow with "no strip".

Leader Elastagraph™ SG

EMISSION REDUCTION GASKETS



Elastagraph™ SG consists of a corrugated metal carrier which is faced with graphite on both sides. The corrugated form of Elastagraph™ SG guarantees a very good flexibility against the flange surfaces. Applying the Graphite layer to the carrier's grooves in the manufacturing process improves the bolt force of the initial torque, as the entire ring edge is not immediately compressed. This creates a line pressure which significantly increases the sealing behavior in comparison to classical gaskets. The core is also made of stainless steel and can withstand potential damage.

Applications

- Pipes (DIN / ANSI / Special dimensions such as full pipe or full face)
- Heat exchanger
- Fixed equipment
- Boilers

Approvals



MIN/MAX GASKET STRESS VALUES			
STYLE	Y VALUE PSI	Optimal PSI	max. PSI
Elastagraph™-SG			
Graphite Facing	5,000	10,000 to 25,000	40,000
ePTFE Facing	5,000	10,000 to 25,000	40,000

Latest version of productdatasheet available on www.leadergt.com

Properties

Metal Core

- Thickness: .024" nominal (pipe Flg.) 1/32" nominal (equipment Flg.)
- Standard 1.4404 (316L ss)
- Higher alloy materials are available

Soft material layer

- Thickness: .020" and .030"
- Inhibited grade graphite: (-400 to 850 F)
- Super inhibited grade graphite (-400 to 975 F)
- ePTFE: (-450 to 500 F)

Pressure

- Rated for ASME B16.5 class 150, 300, 600 pipe flanges.
- Equipment flange gaskets are rated up to 3,000 psi depending on the installation and surface pressure applied.

Types (forms)

- Round, square, oval
- With seam gaps according to drawing

Special Features

- High compressibility
- Good sealing characteristics at low bolt load
- Good adaptability to rough or uneven flange surfaces
- Good adaptability even with on pitted surfaces
- Very high fault tolerance in assembly and operation
- Very good recovery
- Good mechanical properties at high temperature
- Manufactured to special dimensions on request

STYLES OF LEADER ELASTAGRAPH™ SG GASKET

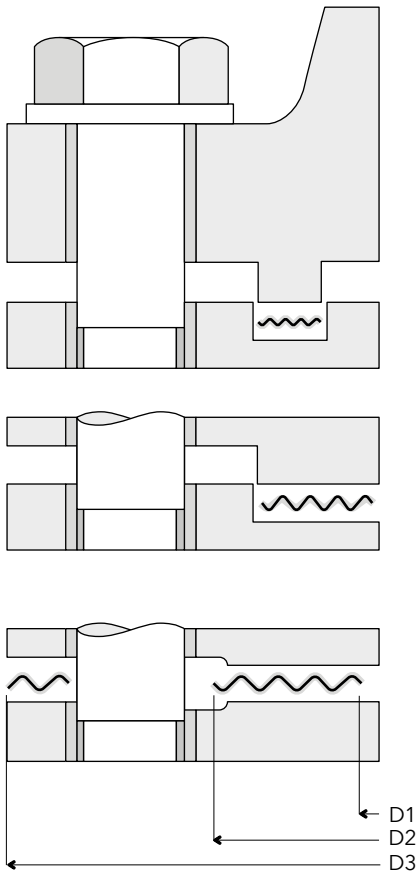

COLOR CODE CHART - ASME B16.20						
Material	Minimum		Maximum		Abbreviation	Guide Ring Color Code
	°F	°C	°F	°C		
304 Stainless Steel	-320	-195	1400	760	304	Yellow
316L Stainless Steel	-328	-200	1600	870	316L	Green
317L Stainless Steel	-150	-100	1600	870	317L	Maroon
321 Stainless Steel	-320	-195	1600	870	321	Turquoise
347 Stainless Steel	-320	-195	1600	870	347	Blue
Carbon Steel	-40	-40	1000	540	CRS	Silver
20Cb-3 (Alloy 20)	-300	-185	1400	760	A-20	Black
HASTELLOY® B 2	-300	-185	2000	1090	HAST B	Brown
HASTELLOY® C 276	-300	-185	2000	1090	HAST C	Beige
INCOLOY® 800	-150	-100	1600	870	IN 800	White
INCONEL® 600	-150	-100	2000	1090	INC 600	Gold
INCONEL® X750	-328	-200	1500	820	INX	No Color
MONEL® 400	-200	-130	1500	820	MON	Orange
Nickel 200	-320	-195	1400	760	NI	Red
Titanium	-320	-195	2000	1090	TI	Purple

Temperatures are for guideline only

Note: All Elastagraph SG pipe flange gaskets are painted yellow around the entire circumference to provide visibility of the actual color strip per the above chart due to the dark appearance of graphite. Exception: 304ss core will be solid yellow with "no strip".

Exchanger & fixed Equipment gaskets are not color coded due to possible paint contamination of the process. However, the metal substrate type/designation is stamped on the facing material and also listed on packaging label.

Other materials available on request
 * the information listed here is not claimed to be exhaustive and serves only as a guide; despite careful content control we assume no liability or guarantee for the topicality, correctness and completeness of the information provided
 ** (to 1000 °F only after consultation)

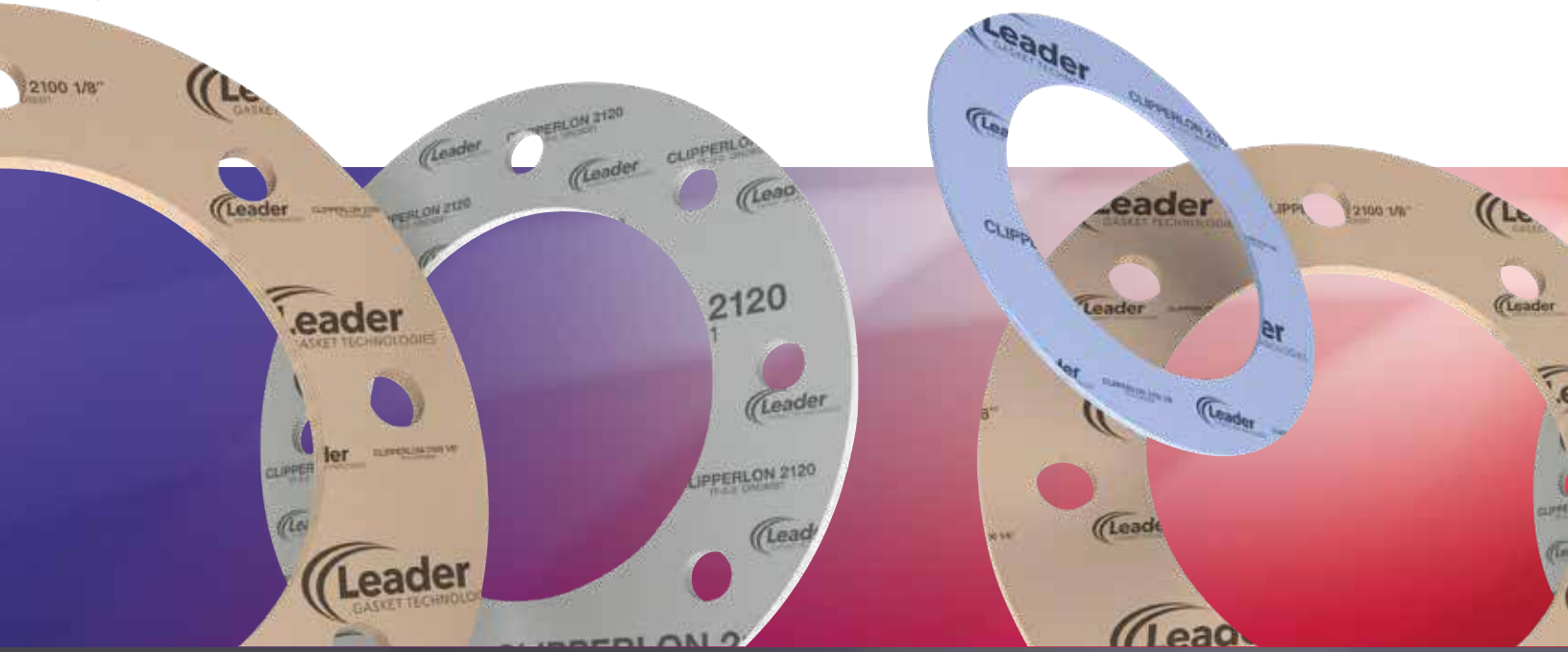

PTFE SHEETS AND GASKETS

Leader Clipperlon 2100

MODIFIED PTFE SHEET (GASKET) WITH SILICA FILLER

The finely divided silica filler gives a very good cold flow resistance and good stress retention properties, even at elevated temperatures. Because of the low diffusion properties and uniform structure, Clipperlon 2100 is the ideal sealing material for applications with the highest demands for low emissions.



Applications

- Pipes (DIN/ANSI)
- TA-Luft
- Grooved flanges
- Heat exchanger
- Equipment
- Cable glands
- For high surface pressure
- For highly aggressive media
- In the full pH range
- Temperature-stressed components

Properties

- Can be used from **-450°F to approx. 500°F**, depending on the installation and operating conditions
- **Max. 1200 PSI**, depending on the installation and operating conditions (*- pressure and temperatures not to be used simultaneously)
- 100% modified PTFE with inorganic filler
- Filling: Silica
- Greatly reduced cold flow
- High stability under thermal load
- Chemically inert (with the exception of melted alkali metals and elemental fluorine)

Sheet format

- 60" x 60", special (formats are available)

Thickness

- 1/64", 1/32", 1/16", 1/8" (special thicknesses are available)

Approvals



SURFACE PRESSURE LIMITS			
STYLE	TEMP. F	min. PSI	max. PSI
Clipperlon			
2100	70	3625	21750
1/16" mm	400	3625	14500

Latest version of productdatasheet available on www.leadergt.com

Leader Clipperlon 2110

MODIFIED PTFE SHEET (GASKET) WITH HOLLOW GLASS MICROSPHERE FILLER

Uniform version of the hollow microsphere filler leads to a low density material with low sealing stress and good adaptability to rough or uneven flanges. Low leakage rate and low creep leads to safe sealing. Clipperlon 2110 is a general purpose PTFE sealing material for all flange connections, also for flanges with easily damaged sealing surfaces (including glass lining) and it also has good electrical insulating properties for where electrical isolation is required.



Applications

- Flanged Pipes (DIN/ANSI)
- TA-Luft
- Glass, ceramic or plastic flanges
- Enamelled pipe flanges
- Steel flanges
- Heat exchanger
- Equipment
- For low surface stress sealing
- For highly aggressive media
- In the full pH range.
- For damaged sealing surfaces
- For pressure-sensitive components

Properties

- Can be used from **-410°F to approx. 500°F**, depending on the installation and operating conditions
- **Max. 800 PSI**, depending on the installation and operating conditions (*- pressure and temperatures not to be used simultaneously)
- 100% modified PTFE filled with micro-hollow glass balls
- Greatly reduced cold flow
- High compressibility and flexibility
- Very good resistance
- Residue free removal
- Chemically inert (with the exception of melted alkali metals and elemental fluorine)

Sheet format

- 60" x 60" (special formats are available)

Thickness

- 1/64", 1/32", 1/16", 1/8" (special thicknesses are available)

Approvals



SURFACE PRESSURE LIMITS			
STYLE	TEMP. F	min. PSI	max. PSI
Clipperlon			
2110	70	2175	21750
1/16"	400	2175	10150

Latest version of productdatasheet available on www.leadergt.com

Clipperlon 2115

USP VI PIGMENT FREE

NATURAL WHITE MODIFIED PTFE PLATE (SEAL) WITH HOLLOW GLASS MICROSPHERES

Modified PTFE, free of pigments, specifically for pharmaceutical, food, and applications where high purity is required.

Uniform distribution of the hollow microsphere filler leads to a low density material with low sealing stress and good adaptability to rough or uneven flanges. Low leakage rate and low creep leads to safe sealing. Clipperlon 2115 is a general - purpose PTFE sealing material for all flange connections, also for flanges with easily damaged sealing surfaces (including glass lining) and it also has good electrical insulating properties for where electrical isolation is required.

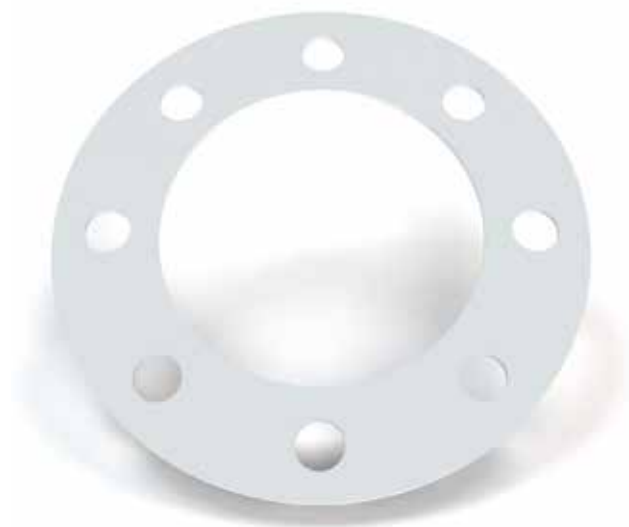

Applications

- Flanged Pipes (DIN/ANSI)
- TA-Luft
- Glass, ceramic or plastic flanges
- Enamelled pipe flanges
- Steel flanges
- Heat exchanger
- Plant / Containers
- For low surface stress sealing
- For highly aggressive media in the full pH range.
- For damaged sealing surfaces
- For pressure-sensitive components
- Direct contact with medium

Properties

- Can be used from **-410°F to approx. 500°F**, depending on the installation and operating conditions
- **Max. 800 PSI**, depending on the installation and operating conditions (*- pressure and temperatures not to be used simultaneously)
- 100% modified PTFE filled with hollow glass microspheres
- Greatly reduced cold flow
- High compressibility and flexibility
- Very good heat and chemical resistance
- Residue free removal
- Chemically inert (with the exception of melted alkali metals and elemental fluorine)

Sheet format

- 60" x 60"

Thickness

- 1/64", 1/32", 1/16", 1/8" (special thicknesses are available)

Approvals



SURFACE PRESSURE LIMITS			
STYLE	TEMP. F	min. PSI	max. PSI
Clipperlon			
2115 1/16"	70	2900	8700
	400	2900	7250

Latest version of productdatasheet available on www.leadertgt.com

Leader Clipperlon 2120

MODIFIED PTFE SHEET (GASKET) WITH BARIUM SULFATE FILLER

Modified PTFE gasket material containing biaxial orientated chains to obtain a tight seal for demanding applications. Clipperlon 2120 is a very dense material with low compressibility, high recovery and low creep properties. Off-white in color and produced with Modified PTFE and barium sulfate filler. Clipperlon 2120 particularly suitable for use with hydrofluoric acid and chlorine applications and a wide variety of different media across the whole pH-range. Due to the high density this material is highly recommended for applications with monomers to avoid the 'popcorning' effect. This effect will be result when the monomer enters the micro-voids of the PTFE



Applications

- Flanged Pipes (DIN/ANSI)
- Chlorine Applications
- Good electronical insulation properties
- TA-Luft
- Steel flanges
- Heat exchanger
- Equipment
- Chlorine Applications
- For highly aggressive media
- In the full pH range

Properties

- Can be used from **-450°F to approx. 500°F**, depending on the installation and operating conditions
- **Max. 1200 PSI**, depending on the installation and operating conditions (*- pressure and temperatures not to be used simultaneously)
- 100% modified PTFE filled with barium sulfate
- Greatly reduced cold flow
- High compressibility and flexibility
- Very good resistance
- Residue free removal
- Chemically inert (with the exception of melted alkali metals and elemental fluorine)

Sheet format

- 60" x 60" (special formats are available)

Thickness

- 1/64", 1/32", 1/16", 1/8" (special thicknesses are available)

Approvals



SURFACE PRESSURE LIMITS			
STYLE	TEMP. F	min. PSI	max. PSI
Clipperlon			
2120 1/16"	70	3625	21750
	400	3625	14500

Latest version of productdatasheet available on www.leadergdt.com

Leader Clipperlon 2130

100% PURE MULTI-DIRECTIONAL EXPANDED PTFE

Clipperlon 2130 gasket sheets are made of 100% pure, multi-directional expanded PTFE, with virtually unlimited chemical resistance. When installed, Clipperlon gaskets provide exceptionally good adaptability to flange roughness and unevenness. A high surface pressure is maintained in operation under pressure and Temperature load.

Clipperlon 2130 achieves very good stability and tightness with good blow-out resistance especially in demanding steel flange applications. The good resistance behavior of the material leads to increased operating safety, even in changing operating conditions.



Applications

- Flanged Pipes (DIN/ANSI)
- TA-Luft
- Steel and enamel flanges
- Heat exchanger
- Equipment
- For high surface stress
- For highly aggressive media
- In the full pH range.
- For damaged sealing surfaces

Properties

- Can be used from **-450°F to approx. 500°F**, depending on the installation and operating conditions
- **Max. 3000 PSI**, depending on the installation and operating conditions (*- pressure and temperatures not to be used simultaneously)
- 100% pure multi-directional expanded PTFE
- No cold flow
- Good adaptability to surface irregularities
- Low creep relaxation
- Residue free removal
- Chemically inert (with the exception of melted alkali metals and elemental fluorine)

Sheet format

- 60" x 60" (special formats are available)

Thickness

- 1/32", 1/16", 1/8" (special thicknesses are available)

Approvals



SURFACE PRESSURE LIMITS			
STYLE	TEMP. F	min. PSI	max. PSI
Clipperlon			
2130 1/16"	70	3625	21750
	400	3625	8700

Latest version of productdatasheet available on www.leadergt.com

Leader Clipperlon 2135

FOOD & PHARMA CONFORMING MULTIDIRECTIONAL ePTFE

Clipperlon 2135 gasket sheets are made of 100% pure, multi-directional expanded PTFE, with virtually unlimited chemical resistance. When installed, Clipperlon gaskets provide exceptionally good adaptability to flange roughness and unevenness. A high surface pressure is maintained in operation under pressure and temperature load.

Clipperlon 2135 achieves very good stability and tightness with good blow-out resistance especially in demanding steel flange applications. The good resistance behaviour of the material leads to increased operating safety, even in changing operating conditions.



Applications

- Flanged Pipes (DIN/ANSI)
- TA-Luft
- Steel and enamel flanges
- Heat exchanger
- Plant / Containers
- For high surface stress
- For highly aggressive media
- in the full pH range.
- For damaged sealing surfaces
- Ink - free sheet marking for food / pharma application

Properties

- Can be used from **-450°F to approx. 500°F**, depending on the installation and operating conditions
- **Max. 580 PSI**, depending on the installation and operating conditions (*- pressure and temperatures not to be used simultaneously)
- 100% pure multi-directional expanded PTFE
- No cold flow
- good adaptability to surface irregularities
- Low creep relaxation
- Residue free removal
- Chemically inert (with the exception of melted alkali metals and elemental fluorine)

Sheet format

- 60" x 60"

Thickness

- 1/32", 1/16", 1/8" (special thicknesses are available)

Approvals



Latest version of productdatasheet available on www.leadergt.com

Leader Clipperlon 600

MONODIRECTIONAL ePTFE JOINT SEALANT

Leader Clipperlon 600 Joint Sealant is made from 100% pure expanded PTFE.

The universal gasket tape forms a thin, but yet strong, reliable gasket under compression, that is highly resistant to aggressive media and chemically inert.

Even for the sealing of large, complex and damaged flanges - just peel of the covering paper from the adhesive backing and stick the Joint Sealant tape to the sealing surface - overlap the endings and close the jointing.



Sealing characteristics

- chemically inert
- highly compressible and conformable
- easy and quick installation
- ideal for large sealing surfaces
- reduces scrap and sealing costs

Chemical compatibility, pressure and temperature

- Particularly for use with aggressive chemicals from pH 0 to 14 (except for molten alkali metals and elemental fluorine gas)
- Pressure up to 580 PSI (higher pressures depending on the individual installation)
- Temperature from -450 °F up to 500 °F

Delivery options

- joint Sealant standard sizes and roll lengths

Approvals and certificates

- DVGW
- TÜV - MUC-KSP-A066
- BAM for gaseous Oxygen
- FDA 21 CFR 177.1550 (PTFE)
- FDA 21 CFR 175.105 (Adhesive)
- USP Class VI (not intended for implantation into the human body) on PTFE
- TA-Luft for steel components



JOINT SEALANT STANDARD SIZES AND ROLL LENGTHS:			
Size [mm]	Spool Length [ft]		
3 x 1			100
5 x 2		75	100
7 x 2,5		50	100
10 x 3	25	50	100
14 x 5	15	30	50
17 x 6	15	30	50
20 x 7	15	30	50
25 x 10	15	30	75

Latest version of productdatasheet available on www.leadergt.com

Leader Clipperlon 660

MULTIDIRECTIONAL ePTFE GASKET TAPE

Leader Clipperlon 660 is the new generation of multidirectionally expanded PTFE gasket tapes for use in pipeline and apparatus flanges.

The optimized fibre structure of this material leads to significantly improved creep resistance and a lower compressive creep, compared to the products used so far. Leader Clipperlon 660 is self-adhesive on one side, flexible and compressible. Due to the high conformability the gasket adapts optimally to flange roughness and unevenness.

Leader Clipperlon 660 is made from 100% pure multidirectionally expanded PTFE. Therefore it offers an excellent chemical resistance, also in highest demanding applications.

Due to the use of high quality raw materials and the regulated manufacturing process this gasket tape is GMP conforming.

Sealing characteristics

- chemical inert
- high creep resistance
- highly conformable to the sealing surface
- low leak rate
- suitable for high temperatures
- individual shaping and fast assembly

Chemical compatibility, pressure and temperature

- Particularly for use with aggressive chemicals from pH 0 to 14 (except for molten alkali metals and elemental fluorine gas)
- Pressure up to 750 PSI (higher pressures depending on the individual installation)
- Temperature from -450 °F up to 500 °F

Delivery options

- Gasket Tape Widths from 10 mm to 65 mm
- Thickness 2 mm, 3 mm, 6 mm and 9 mm
- Standard Roll Length 15ft, 30ft or 50ft



Approvals and certificates

- FDA 21 CFR 177.1550 (PTFE)
- FDA 21 CFR 175.105 (Adhesive)
- EC1935 (10/2011 - 2023/2006)
- USP Class VI (not intended for implantation into the human body) on PTFE
- BAM for gaseous and liquid Oxygen
- Blow-Out certified acc. VDI 2200
- TA-Luft for steel components
- TA-Luft for glass lined components



OEM Custom Made Gaskets

CO-ENGINEERING SPECIAL AND CUSTOM MADE GASKETS



Leader Gasket develops and manufactures special and custom made seals and gaskets according to customer specifications for various OEM and customized applications. Our engineering team has extensive experience in working together with customers in Co engineering projects in the automotive industry and other industries where special machinery and equipment is manufactured.

Engineering Team

Our engineering team can provide the engineering expertise and capability to develop, plan, design and build the solutions for any application in the OEM Industry. We pride ourselves in successfully co-engineering products with customers that meet their specific requirements with approved procedures, tests - LDC, Room Temperature Leakage and others.

Special Gaskets

Gaskets are produced in different styles special types for the most demanding applications in, such as:

- Automotive industry
- Exhaust and manifold gaskets
- Valves
- Heat exchanger
- Heating and cooling equipment
- Special machinery and others

Customer Base

Leader Gasket supplies special produced gaskets to many OEM customers around the world. In the automotive industry we work together with major car and truck manufacturers and component suppliers for engines.

Our Approach

With both multinationals and small, specialized companies in the manufacturing industry, we sit down together at an early stage of engineering with R&D employees to work together on the perfect product.

Leader Gasket and its allied distributors has very experienced Application Engineers who work closely with our customers to give advise and guide you through the design, prototyping, and testing process. By working in this way, we contribute to the achievement of your ambition to quickly and successfully introduce new products or innovative power. Starting from brainstorming on ideas, followed in the end of the process by first sample and mass production of your part.

Documentation Quality

At Leader Gasket several quality processes and documentation are in place supporting and contributing OEM and Automotive develop, design, and manufacturing projects; such as:

- EMPB PPAP ISIR procedure First Sample Reporting
- APQP flowchart
- Fabrication Control Plan
- Customer in-house specific documentation
- Batch Control System

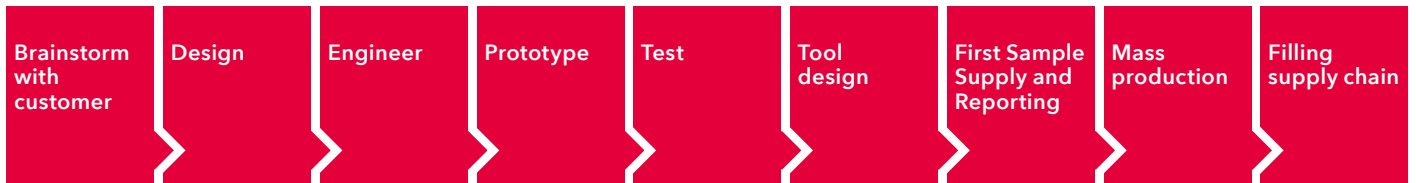

Engineering Team

Feel free to contact or challenge our Engineering Team with your projects.



LeaderTHERM

LeaderTHERM consists of impregnated phlogopite mica flake structure. Mica, an aluminosilicate of mineral origin, has a lamellar and non fibrous structure representing an excellent alternative to asbestos at high temperatures. This material gives LeaderTHERM Sheet its thermal characteristics - weight loss at 800 C (1472 F) less than 5% - and its chemical resistance to solvents, acids, bases and mineral oils.

LeaderTHERM Sheet is developed specifically for high temperature applications (up to 1800F) as a sheet material, filler for spiral wound gaskets or facing for kammprofiles. The material offers outstanding resistance to elevated temperatures as well as good sealability at moderate pressures.

Applications

- Exhaust manifolds
- Gas turbines
- Gas and oil burners
- Heat exchanger

Operating Limits

- Maximum continuous service temperature 1800F
- LeaderTHERM Sheet & Tanged rated to a maximum of 80 psi
- Spiral wound style *SRI-LTD rated to 1500F for ASME B16.5 Class 150 to 2500
- Spiral wound style SRI-LT (LeaderTHERM "only" filler) consult with LGT engineering dept.
- Spiral wound style SRI-LCL (LeaderTHERM "only" filler & Kamprofile Inner Ring Facing) consult with LGT engineering dept.
- LeaderKAM with hybrid facing (inhibited graphite and LeaderTHERM combination) rated to 1500°F for ASME B16.5

* Hybrid spiral wound gasket with (3) LeaderTHERM wraps on O.D. and remaining wraps of inhibited grade graphite. Oxidizing processes will require an additional (3) wraps of Leadertherm on I.D.

ASME Values for Sheet

- M= 3.5
- Y= 4350 psi



Technical Data

- | | |
|---|-------------------------|
| ▪ Thickness: | 0.1 - 3 mm |
| ▪ Density (IEC 371-2): | 2.0 g / cm ³ |
| ▪ Tensile Strength (DIN 52910): | 20 N / mm ² |
| ▪ Compressibility (ASTM F36J): | 25% |
| ▪ Recovery (ASTM F36-J): | 35% |
| ▪ Residual Stress (BS7531): | 33 Mpa |
| ▪ Dielectric Strength (IEC 243 - 23°C): | + 20 kV/mm |
| ▪ Creep Strength (DIN 52913) | |
| ▪ 50 Mpa, 300°C * | |
| ▪ 7252 psi, 572°F * | |

* The measurement was performed on LeaderTHERM Sheet with a tanged steel insert.

Availability

- In rolls or sheets or as winding strip for spiral wound gaskets. Available thicknesses 0.8mm, 1.0mm, 1.5mm, 2.0mm, 3.0mm

Storage

- Should be stored in a cool dry place away from sources of humidity. Prior to installation, product must be kept dry and free of moisture. In the event of exposure to moisture, the product must be allowed to dry completely before installation.

HPLE Flexible Graphite

HIGH PERFORMANCE LOW EMISSIONS FLEXIBLE GRAPHITE

Leader HPLE is the highest inhibited grade of flexible graphite meeting the most stringent graphite requirements on temperature, weightloss and emission rates on flange gaskets set by the global industries. Leader Gasket has standardized on this grade of HPLE graphite as minimum requirement for all spiral wounds and kammprofile gaskets.



PROPERTIES:	
Density	1.04 g/cm ³ (64.9 lb/ft ³) Tolerance +/- 0.7 g/cm ³
Ash Content	2% max.
Carbon Content	98% min.
Leachable Chlorides (CL)	50 ppm max.
Sulfur Content (S)	750 ppm max.
Fluorine Content (F)	10 ppm max.
Total Halogen Content (chlorine, bromine, & fluorine)	310 ppm max.
TGA Oxidation Weight Loss Test	Below < 4% per hour 1238 °F for 4 hrs. per In accordance with EN14772 Section 6.7

Flange gaskets*

Gaskets according to ASME B16.21 (2016)

For flanges according to ASME/ANSI B16.5

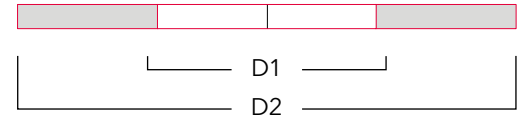

CLASS	150		300		400		600		900		
	NPS (inch)	D1	D2	D1	D2	D1	D2	D1	D2	D1	D2
1/2"		0.84	1.88	0.84	2.12	0.84	2.12	0.84	2.12	0.84	2.50
3/4"		1.06	2.25	1.06	2.62	1.06	2.62	1.06	2.62	1.06	2.75
1"		1.31	2.62	1.31	2.88	1.31	2.88	1.31	2.88	1.31	3.12
1 1/4"		1.66	3.00	1.66	3.25	1.66	3.25	1.66	3.25	1.66	3.50
1 1/2"		1.91	3.38	1.91	3.75	1.91	3.75	1.91	3.75	1.91	3.88
2"		2.38	4.12	2.38	4.38	2.38	4.38	2.38	4.38	2.38	5.62
2 1/2"		2.88	4.88	2.88	5.12	2.88	5.12	2.88	5.12	2.88	6.50
3"		3.50	5.38	3.50	5.88	3.50	5.88	3.50	5.88	3.50	6.62
3 1/2"		4.00	6.38	4.00	6.50	4.00	6.38	4.00	6.38	-	-
4"		4.50	6.88	4.50	7.12	4.50	7.00	4.50	7.62	4.50	8.12
5"		5.56	7.75	5.56	8.50	5.56	8.38	5.56	9.50	5.56	9.75
6"		6.62	8.75	6.62	9.88	6.62	9.75	6.62	10.50	6.62	11.38
8"		8.62	11.00	8.62	12.12	8.62	12.00	8.62	12.62	8.62	14.12
10"		10.75	13.38	10.75	14.25	10.75	14.12	10.75	15.75	10.75	17.12
12"		12.75	16.12	12.75	16.62	12.75	16.50	12.75	18.00	12.75	19.62
14"		14.00	17.75	14.00	19.12	14.00	19.00	14.00	19.38	14.00	20.50
16"		16.00	20.25	16.00	21.25	16.00	21.12	16.00	22.25	16.00	22.62
18"		18.00	21.62	18.00	23.50	18.00	23.38	18.00	24.12	18.00	25.12
20"		20.00	23.88	20.00	25.75	20.00	25.50	20.00	26.88	20.00	27.50
24"		24.00	28.25	24.00	30.50	24.00	30.25	24.00	31.12	24.00	33.00

*Despite careful content control we assume no liability or guarantee for the topicality, correctness and completeness of the information provided

Flange gaskets*

Gaskets according to ASME B16.21 (2016)

For flanges according to ASME/ANSI B16.47 Series A

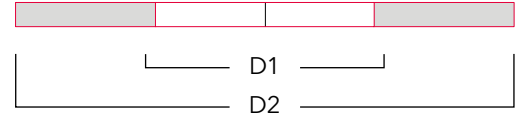

CLASS	150		300		400		600	
NPS (inch)	D1	D2	D1	D2	D1	D2	D1	D2
26	26.00	30.50	26.00	32.88	26.00	32.75	26.00	34.12
28	28.00	32.75	28.00	35.38	28.00	35.12	28.00	36.00
30	30.00	34.75	30.00	37.50	30.00	37.25	30.00	38.25
32	32.00	37.00	32.00	39.62	32.00	39.50	32.00	40.25
34	34.00	39.00	34.00	41.62	34.00	41.50	34.00	42.25
36	36.00	41.25	36.00	44.00	36.00	42.25	36.00	44.50
38	38.00	43.75	38.00	41.50	38.00	42.26	38.00	43.50
40	40.00	45.75	40.00	43.88	40.00	44.38	40.00	45.50
42	42.00	48.00	42.00	45.88	42.00	46.38	42.00	48.00
44	44.00	50.25	44.00	48.00	44.00	48.50	44.00	50.00
46	46.00	52.25	46.00	50.12	46.00	50.75	46.00	52.25
48	48.00	54.50	48.00	52.12	48.00	53.00	48.00	54.75
50	50.00	56.50	50.00	54.25	50.00	55.25	50.00	57.00
52	52.00	58.75	52.00	56.25	52.00	57.26	52.00	59.00
54	54.00	61.00	54.00	58.75	54.00	59.75	54.00	61.25
56	56.00	63.25	56.00	60.75	56.00	61.75	56.00	63.50
58	58.00	65.50	58.00	62.75	58.00	63.75	58.00	65.50
60	60.00	67.50	60.00	64.75	60.00	66.25	60.00	67.75

*Despite careful content control we assume no liability or guarantee for the topicality, correctness and completeness of the information provided

Flange gaskets*

Gaskets according to ASME B16.21 (2016)

For flanges according to ASME/ANSI B16.47 Serie B

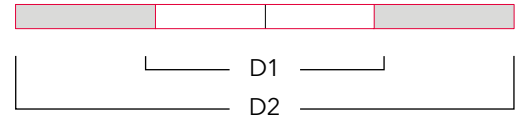

CLASS	75		150		300		400		600	
	NPS (inch)	D1	D2	D1	D2	D1	D2	D1	D2	D1
26	26.00	27.88	26.00	28.56	26.00	30.38	26.00	29.38	26.00	30.12
28	28.00	29.88	28.00	30.56	28.00	32.50	28.00	31.50	28.00	32.25
30	30.00	31.88	30.00	32.56	30.00	34.88	30.00	33.75	30.00	34.62
32	32.00	33.88	32.00	34.69	32.00	37.00	32.00	35.88	32.00	36.75
34	34.00	35.88	34.00	36.81	34.00	39.12	34.00	37.88	34.00	39.25
36	36.00	38.31	36.00	38.88	36.00	41.25	36.00	40.25	36.00	41.25
38	38.00	40.31	38.00	41.12	38.00	43.25				
40	40.00	42.31	40.00	43.12	40.00	45.25				
42	42.00	44.31	42.00	45.12	42.00	47.25				
44	44.00	46.50	44.00	47.12	44.00	49.25				
46	46.00	48.50	46.00	49.44	46.00	51.88				
48	48.00	50.50	48.00	51.44	48.00	53.88				
50	50.00	52.50	50.00	53.44	50.00	55.88				
52	52.00	54.62	52.00	55.44	52.00	57.88				
54	54.00	56.62	54.00	57.62	54.00	60.25				
56	56.00	58.88	56.00	59.62	56.00	62.75				
58	58.00	60.88	58.00	62.19	58.00	65.19				
60	60.00	62.88	60.00	64.19	60.00	67.12				

*Despite careful content control we assume no liability or guarantee for the topicality, correctness and completeness of the information provided

Flange gaskets*

Spiral wound gaskets according to ASME B16.20 (2017)

For flanges according to ASME/ANSI B16.5

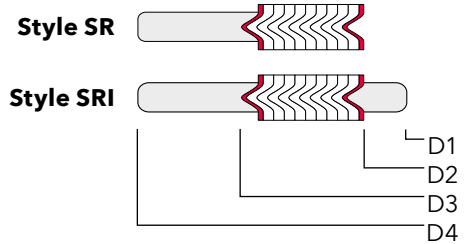

NPS (inch)	CLASS 150				CLASS 300				CLASS 400			
	D1	D2	D3	D4	D1	D2	D3	D4	D1	D2	D3	D4
1/2	0.56	0.75	1.25	1.88	0.56	0.75	1.25	2.13	0.56	0.75	1.25	2.13
3/4	0.81	1.00	1.56	2.25	0.81	1.00	1.56	2.63	0.81	1.00	1.56	2.63
1	1.06	1.25	1.88	2.63	1.06	1.25	1.88	2.88	1.06	1.25	1.88	2.88
1 1/4	1.50	1.88	2.38	3.00	1.50	1.88	2.38	3.25	1.50	1.88	2.38	3.25
1 1/2	1.75	2.13	2.75	3.38	1.75	2.13	2.75	3.75	1.75	2.13	2.75	3.75
2	2.19	2.75	3.38	4.13	2.19	2.75	3.38	4.38	2.19	2.75	3.38	4.38
2 1/2	2.62	3.25	3.88	4.88	2.62	3.25	3.88	5.13	2.62	3.25	3.88	5.13
3	3.19	4.00	4.75	5.38	3.19	4.00	4.75	5.88	3.19	4.00	4.75	5.88
3 1/2	3.98	4.50	5.25	6.38	3.98	4.50	5.25	6.50	3.60	4.13	5.25	6.38
4	4.19	5.00	5.88	6.88	4.19	5.00	5.88	7.13	4.04	4.75	5.88	7.00
5	5.19	6.13	7.00	7.75	5.19	6.13	7.00	8.50	5.05	5.81	7.00	8.38
6	6.19	7.19	8.25	8.75	6.19	7.19	8.25	9.88	6.10	6.88	8.25	9.75
8	8.50	9.19	10.38	11.00	8.50	9.19	10.38	12.13	8.10	8.88	10.38	12.00
10	10.56	11.31	12.50	13.38	10.56	11.31	12.50	14.25	10.05	10.81	12.50	14.13
12	12.50	13.38	14.75	16.13	12.50	13.38	14.75	16.63	12.10	12.88	14.75	16.50
14	13.75	14.63	16.00	17.75	13.75	14.63	16.00	19.13	13.50	14.25	16.00	19.00
16	15.75	16.63	18.25	20.25	15.75	16.63	18.25	21.25	15.35	16.25	18.25	21.13
18	17.69	18.69	20.75	21.63	17.69	18.69	20.75	23.50	17.25	18.50	20.75	23.38
20	19.69	20.69	22.75	23.88	19.69	20.69	22.75	25.75	19.25	20.50	22.75	25.50
24	23.75	24.75	27.00	28.25	23.75	24.75	27.00	30.50	23.25	24.75	27.00	30.25

NPS (inch)	CLASS 600				CLASS 900				CLASS 1500				CLASS 2500			
	D1	D2	D3	D4	D1	D2	D3	D4	D1	D2	D3	D4	D1	D2	D3	D4
1/2	0.56	0.75	1.25	2.13	0.56	0.75	1.25	2.50	0.56	0.75	1.25	2.50	0.56	0.75	1.25	2.75
3/4	0.81	1.00	1.56	2.63	0.81	1.00	1.56	2.75	0.81	1.00	1.56	2.75	0.81	1.00	1.56	3.00
1	1.06	1.25	1.88	2.88	1.06	1.25	1.88	3.13	1.06	1.25	1.88	3.13	1.06	1.25	1.88	3.38
1 1/4	1.50	1.88	2.38	3.25	1.31	1.56	2.38	3.50	1.31	1.56	2.38	3.50	1.31	1.56	2.38	4.13
1 1/2	1.75	2.13	2.75	3.75	1.63	1.88	2.75	3.88	1.63	1.88	2.75	3.88	1.63	1.88	2.75	4.63
2	2.19	2.75	3.38	4.38	2.06	2.31	3.38	5.63	2.06	2.31	3.38	5.63	2.06	2.31	3.38	5.75
2 1/2	2.62	3.25	3.88	5.13	2.50	2.75	3.88	6.50	2.50	2.75	3.88	6.50	2.50	2.75	3.88	6.63
3	3.19	4.00	4.75	5.88	3.10	3.75	4.75	6.63	3.10	3.63	4.75	6.88	3.10	3.63	4.75	7.75
3 1/2	3.60	4.13	5.25	6.38	-	-	-	-	-	-	-	-	-	-	-	-
4	4.04	4.75	5.88	7.63	4.04	4.75	5.88	8.13	3.85	4.63	5.88	8.25	3.85	4.63	5.88	9.25
5	5.05	5.81	7.00	9.50	5.05	5.81	7.00	9.75	4.90	5.63	7.00	10.00	4.9	5.63	7.00	11.00
6	6.10	6.88	8.25	10.50	6.10	6.88	8.25	11.38	5.80	6.75	8.25	11.13	5.8	6.75	8.25	12.50
8	8.10	8.88	10.38	12.63	7.75	8.75	10.13	14.13	7.75	8.50	10.13	13.88	7.75	8.50	10.13	15.25
10	10.05	10.81	12.50	15.75	9.69	10.88	12.25	17.13	9.69	10.50	12.25	17.13	9.69	10.63	12.25	18.75
12	12.10	12.88	14.75	18.00	11.50	12.75	14.50	19.63	11.5	12.75	14.50	20.50	11.5	12.50	14.50	21.63
14	13.50	14.25	16.00	19.38	12.63	14.00	15.75	20.50	12.63	14.25	15.75	22.75				
16	15.35	16.25	18.25	22.25	14.75	16.25	18.00	22.63	14.5	16.00	18.00	25.25				
18	17.25	18.50	20.75	24.13	16.75	18.25	20.50	25.13	16.75	18.25	20.50	27.75				
20	19.25	20.50	22.75	26.88	19.00	20.50	22.50	27.50	18.75	20.25	22.50	29.75				
24	23.25	24.75	27.00	31.13	23.25	24.75	26.75	33.00	22.75	24.25	26.75	35.50				

*Despite careful content control we assume no liability or guarantee for the topicality, correctness and completeness of the information provided

Flange gaskets*

Spiral wound gaskets according to ASME B16.20 (2017)

For flanges according to ASME/ANSI B16.47 Series A
(formerly API 601 For flanges according to MSS SP-44)

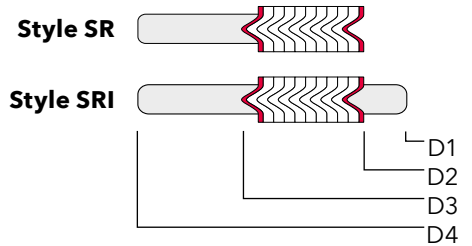

NPS (inch)	CLASS 150				CLASS 300				CLASS 400			
	D1	D2	D3	D4	D1	D2	D3	D4	D1	D2	D3	D4
26	25.75	26.50	27.75	30.50	25.75	27.00	29.00	32.88	26.00	27.00	29.00	32.75
28	27.75	28.50	29.75	32.75	27.75	29.00	31.00	35.38	28.00	29.00	31.00	35.13
30	29.75	30.50	31.75	34.75	29.75	31.25	33.25	37.50	29.75	31.25	33.25	37.25
32	31.75	32.50	33.88	37.00	31.75	33.50	35.50	39.63	32.00	33.50	35.50	39.50
34	33.75	34.50	35.88	39.00	33.75	35.50	37.50	41.63	34.00	35.50	37.50	41.50
36	35.75	36.50	38.13	41.25	35.75	37.63	39.63	44.00	36.13	37.63	39.63	44.00
38	37.75	38.50	40.13	43.75	37.50	38.50	40.00	41.50	37.50	38.25	40.25	42.25
40	39.75	40.50	42.13	45.75	39.50	40.25	42.13	43.88	39.38	40.38	42.38	44.38
42	41.75	42.50	44.25	48.00	41.50	42.25	44.13	45.88	41.38	42.38	44.38	46.38
44	43.75	44.50	46.38	50.25	43.50	44.50	46.50	48.00	43.50	44.50	46.50	48.50
46	45.75	46.50	48.38	52.25	45.38	46.38	48.38	50.13	46.00	47.00	49.00	50.75
48	47.75	48.50	50.38	54.50	47.63	48.63	50.63	52.13	47.50	49.00	52.00	53.00
50	49.75	50.50	52.50	56.50	49.00	51.00	53.00	54.25	49.50	51.00	53.00	55.25
52	51.75	52.50	54.50	58.75	52.00	53.00	55.00	56.25	51.50	53.00	55.00	57.25
54	53.50	54.50	56.50	61.00	53.25	55.25	57.25	58.75	53.25	55.25	57.25	59.75
56	55.50	56.50	58.50	63.25	55.25	57.25	59.25	60.75	55.25	57.25	59.25	61.75
58	57.50	58.50	60.50	65.50	57.00	59.50	61.50	62.75	57.25	59.25	61.25	63.75
60	59.50	60.50	62.50	67.50	60.00	61.50	63.50	64.75	59.75	61.75	63.75	66.25

NPS (inch)	CLASS 600				CLASS 900			
	D1	D2	D3	D4	D1	D2	D3	D4
26	25.50	27.00	29.00	34.13	26.00	27.00	29.00	34.75
28	27.50	29.00	31.00	36.00	28.00	29.00	31.00	37.25
30	29.75	31.25	33.25	38.25	30.25	31.25	33.25	39.75
32	32.00	33.50	35.50	40.25	32.00	33.50	35.50	42.25
34	34.00	35.50	37.50	42.25	34.00	35.50	37.50	44.75
36	36.13	37.63	39.63	44.50	36.25	37.75	39.75	47.25
38	37.50	39.00	41.00	43.50	39.75	40.75	42.75	47.25
40	39.75	41.25	43.25	45.50	41.75	43.25	45.25	49.25
42	42.00	43.50	45.50	48.00	43.75	45.25	47.25	51.25
44	43.75	45.75	47.75	50.00	45.50	47.50	49.50	53.88
46	45.75	47.75	49.75	52.25	48.00	50.00	52.00	56.50
48	48.00	50.00	52.00	54.75	50.00	52.00	54.00	58.50
50	50.00	52.00	54.00	57.00				
52	52.00	54.00	56.00	59.00				
54	54.25	56.25	58.25	61.25				
56	56.25	58.25	60.25	63.50				
58	58.00	60.50	62.50	65.50				
60	60.25	62.75	64.75	68.25				

*Despite careful content control we assume no liability or guarantee for the topicality, correctness and completeness of the information provided

Flange gaskets*

Spiral wound gaskets according to ASME B16.20 (2017)

in accordance with ASME/ANSI B16.47 Series B
(formerly API 601 For flanges according to API 605)

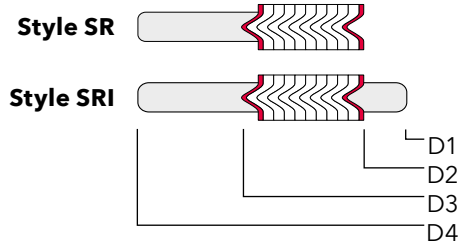

NPS (inch)	CLASS 150				CLASS 300				CLASS 400			
	D1	D2	D3	D4	D1	D2	D3	D4	D1	D2	D3	D4
26	25.75	26.50	27.50	28.56	25.75	26.50	28.00	30.38	25.75	26.25	27.50	29.38
28	27.75	28.50	29.50	30.56	27.75	28.50	30.00	32.50	27.63	28.13	29.50	31.50
30	29.75	30.50	31.50	32.56	29.75	30.50	32.00	34.88	29.63	30.13	31.75	33.75
32	31.75	32.50	33.50	34.69	31.75	32.50	34.00	37.00	31.50	32.00	33.88	35.88
34	33.75	34.50	35.75	36.81	33.75	34.50	36.00	39.13	33.50	34.13	35.88	37.88
36	35.75	36.50	37.75	38.88	35.75	36.50	38.00	41.25	35.38	36.13	38.00	40.25
38	37.75	38.38	39.75	41.13	38.25	39.75	41.25	43.25	37.50	38.25	40.25	42.25
40	39.75	40.25	41.88	43.13	40.25	41.75	43.25	45.25	39.38	40.38	42.38	44.38
42	41.75	42.50	43.88	45.13	42.75	43.75	45.25	47.25	41.38	42.38	44.38	46.38
44	43.75	44.25	45.88	47.13	44.25	45.75	47.25	49.25	43.50	44.50	46.50	48.50
46	45.75	46.50	48.19	49.44	46.38	47.88	29.38	51.88	46.00	47.00	49.00	50.75
48	47.75	48.50	50.00	51.44	45.50	49.75	51.63	53.88	47.50	49.00	51.00	53.00
50	49.75	50.50	52.19	53.44	49.88	51.88	53.38	55.88	49.50	51.00	53.00	55.25
52	51.75	52.50	54.19	55.44	51.88	53.88	55.38	57.88	51.50	53.00	55.00	57.25
54	53.75	54.50	56.00	57.63	53.75	55.25	57.25	60.25	53.25	55.25	57.25	59.75
56	56.00	56.88	58.19	59.63	56.25	58.25	60.00	62.75	55.25	57.25	59.25	61.75
58	58.19	59.06	60.19	62.19	58.44	60.44	61.94	65.19	57.25	59.25	61.25	63.75
60	60.44	61.31	62.44	64.19	61.31	62.56	64.19	67.19	59.75	61.75	63.75	66.25

NPS (inch)	CLASS 600				CLASS 900			
	D1	D2	D3	D4	D1	D2	D3	D4
26	25.38	26.13	28.13	30.13	26.25	27.25	29.50	33.00
28	27.00	27.75	29.75	32.25	28.25	29.25	31.50	35.50
30	29.63	30.63	32.63	34.63	30.75	31.75	33.75	37.75
32	31.25	32.75	34.75	36.75	33.00	34.00	36.00	40.00
34	33.50	35.00	37.00	39.25	35.25	36.25	38.25	42.25
36	35.50	37.00	39.00	41.25	36.25	37.25	39.25	44.25
38	37.50	39.00	41.00	43.50	39.75	40.75	42.75	47.25
40	39.75	41.25	43.25	45.50	41.75	43.25	45.25	49.25
42	42.00	43.50	45.50	48.00	43.75	45.25	47.25	51.25
44	43.75	45.75	47.75	50.00	45.50	47.50	49.50	53.88
46	45.75	47.75	49.75	52.25	48.00	50.00	52.00	56.50
48	48.00	50.00	52.00	54.75	50.00	52.00	54.00	58.50
50	50.00	52.00	54.00	57.00				
52	52.00	54.00	56.00	59.00				
54	54.25	56.25	58.25	61.25				
56	56.25	58.25	60.25	63.50				
58	58.00	60.50	62.50	65.50				
60	60.25	62.75	64.75	68.25				

*Despite careful content control we assume no liability or guarantee for the topicality, correctness and completeness of the information provided

Flange gaskets*

LeaderKam Kammprofile gaskets according to ASME B16.20 (2017)

For flanges according to ASME/ANSI B16.5

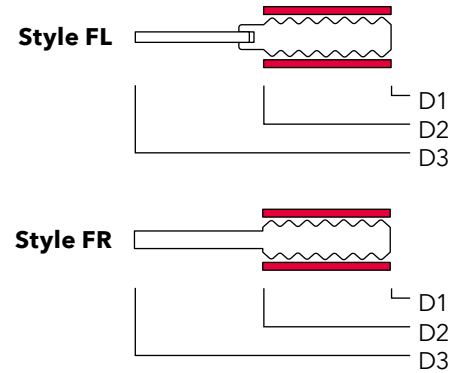

NPS (inch)	GROOVED METAL CORE		CENTERING RING						
	INSIDE DIAMETER	OUTSIDE DIAMETER	OUTSIDE DIAMETER						
	D1	D2	D3						
	150 - 2500	150 - 2500	150 lbs	300 lbs	400 lbs	600 lbs	900 lbs	1500 lbs	2500 lbs
1/2"	0.91	1.31	1.88	2.13	2.13	2.13	2.5	2.5	2.75
3/4"	1.13	1.56	2.25	2.63	2.63	2.63	2.75	2.75	3
1"	1.44	1.87	2.63	2.88	2.88	2.88	3.13	3.13	3.38
1 1/4"	1.75	2.37	3	3.25	3.25	3.25	3.5	3.5	4.13
1 1/2"	2.06	2.75	3.38	3.75	3.75	3.75	3.88	3.88	4.63
2"	2.75	3.5	4.13	4.38	4.38	4.38	5.63	5.63	5.75
2 1/2"	3.25	4	4.88	5.13	5.13	5.13	6.5	6.5	6.63
3"	3.87	4.87	5.38	5.88	5.88	5.88	6.63	6.88	7.75
4"	4.87	6.06	6.88	7.13	7.00	7.63	8.13	8.25	9.25
5"	5.94	7.19	7.75	8.5	8.38	9.5	9.75	10	11
6"	7	8.37	8.75	9.88	9.75	10.5	11.38	11.13	12.5
8"	9	10.5	11	12.13	12.00	12.63	14.13	13.88	15.25
10"	11.13	12.63	13.38	14.25	14.13	15.75	17.13	17.13	18.75
12"	13.37	14.87	16.13	16.63	16.50	18	19.63	20.5	21.63
14"	14.63	16.13	17.75	19.13	19.00	19.38	20.5	22.75	-
16"	16.63	18.37	20.25	21.25	21.13	22.25	22.63	25.25	-
18"	18.87	20.87	21.63	23.5	23.88	24.13	25.13	27.75	-
20"	20.87	22.87	23.88	25.75	25.50	26.88	27.5	29.75	-
24"	24.87	26.87	28.25	30.5	30.25	31.13	33	35.5	-

*Despite careful content control we assume no liability or guarantee for the topicality, correctness and completeness of the information provided

Flange gaskets*

LeaderKam Kammprofile gaskets according to ASME B16.20 (2017)

For flanges according to ASME/ANSI B16.47 Serie A

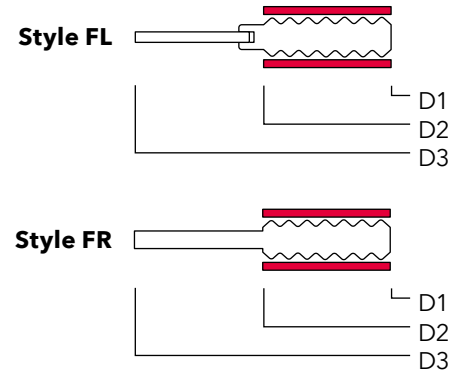

NPS (inch)	GROOVED CORE I.D.					GROOVED CORE O.D.					CENTERING RING O.D.				
	D1					D2					D3				
	150 lbs	300 lbs	400 lbs	600 lbs	900 lbs	150 lbs	300 lbs	400 lbs	600 lbs	900 lbs	150 lbs	300 lbs	400 lbs	600 lbs	900 lbs
26	26.50	27.00	27.00	27.00	27.00	27.75	29.00	29.00	29.00	29.00	30.50	32.88	32.75	34.13	34.75
28	28.50	29.00	29.00	29.00	29.00	29.75	31.00	31.00	31.00	31.00	32.75	35.38	35.13	36.00	37.25
30	30.50	31.25	31.25	31.25	31.25	31.75	33.25	33.25	33.25	33.25	34.75	37.50	37.25	38.25	39.75
32	32.50	33.50	33.50	33.50	33.50	33.88	35.50	35.50	35.50	35.50	37.00	39.63	39.50	40.25	42.25
34	34.50	35.50	35.50	35.50	35.50	35.88	37.50	37.50	37.50	37.50	39.00	41.63	41.50	42.25	44.75
36	36.50	37.63	37.63	37.63	37.63	38.13	39.63	39.63	39.63	39.75	41.25	44.00	44.00	44.50	47.25
38	38.50	38.50	38.25	39.00	39.00	40.13	40.00	40.25	41.00	42.75	43.75	41.50	42.25	43.50	47.25
40	40.50	40.25	40.38	41.25	41.25	42.13	42.13	42.38	43.25	45.25	45.75	43.88	44.38	45.50	49.25
42	42.50	42.25	42.38	43.50	43.50	44.25	44.13	44.38	45.50	47.25	48.00	45.88	46.38	48.00	51.25
44	44.50	44.50	44.50	45.75	45.75	46.38	46.50	46.50	47.75	49.50	50.25	48.00	48.50	50.00	53.88
46	46.50	46.38	47.00	47.75	47.75	48.38	48.38	49.00	49.75	52.00	52.25	50.13	50.75	52.25	56.50
48	48.50	48.63	49.00	50.00	50.00	50.38	50.63	52.00	52.00	54.00	54.50	52.13	53.00	54.75	58.50
50	50.50	51.00	51.00	52.00	-	52.50	53.00	53.00	54.00	-	56.50	54.25	55.25	57.00	-
52	52.50	53.00	53.00	54.00	-	54.50	55.00	55.00	56.00	-	58.75	56.25	57.25	59.00	-
54	54.50	55.25	55.25	56.25	-	56.50	57.25	57.25	58.25	-	61.00	58.75	59.75	61.25	-
56	56.50	57.25	57.25	58.25	-	58.50	59.25	59.25	60.25	-	63.25	60.75	61.75	63.50	-
58	58.50	59.50	59.25	60.50	-	60.50	61.50	61.25	62.50	-	65.50	62.75	63.75	65.50	-
60	60.50	61.50	61.75	62.75	-	62.50	63.50	63.75	64.75	-	67.50	64.75	66.25	68.25	-

*Despite careful content control we assume no liability or guarantee for the topicality, correctness and completeness of the information provided

Flange gaskets*

LeaderKam Kammprofile gaskets according to ASME B16.20 (2017)

For flanges according to ASME/ANSI B16.47 Serie B

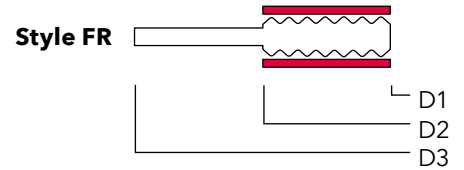
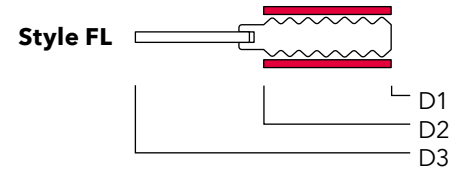

NPS (inch)	GROOVED CORE I.D.					GROOVED CORE O.D.					CENTERING RING O.D.				
	D1					D2					D3				
	150 lbs	300 lbs	400 lbs	600 lbs	900 lbs	150 lbs	300 lbs	400 lbs	600 lbs	900 lbs	150 lbs	300 lbs	400 lbs	600 lbs	900 lbs
26	26.50	26.50	26.25	26.13	27.25	27.50	28.00	27.50	28.13	29.50	28.56	30.38	29.38	30.13	33.00
28	28.50	28.50	28.13	27.75	29.25	29.50	30.00	29.50	29.75	31.50	30.56	32.50	31.50	32.25	35.50
30	30.50	30.50	30.13	30.63	31.75	31.50	32.00	31.75	32.63	33.75	32.56	34.88	33.75	34.63	37.75
32	32.50	32.50	32.00	32.75	34.00	33.50	34.00	33.88	34.75	36.00	34.69	37.00	35.88	36.75	40.00
34	34.50	34.50	34.13	35.00	36.25	35.75	36.00	35.88	37.00	38.25	36.81	39.13	37.88	39.25	42.25
36	36.50	36.50	36.13	37.00	37.25	37.75	38.00	38.00	39.00	39.25	38.88	41.25	40.25	41.25	44.25
38	38.38	39.75	38.25	39.00	40.75	39.75	41.25	40.25	41.00	42.75	41.13	43.25	42.25	43.50	47.25
40	40.25	41.75	40.38	41.25	43.25	41.88	43.25	42.38	43.25	45.25	43.13	45.25	44.38	45.50	49.25
42	42.50	43.75	42.38	43.50	45.25	43.88	45.25	44.38	45.50	47.25	45.13	47.25	46.38	48.00	51.25
44	44.25	45.75	44.50	45.75	47.50	45.88	47.25	46.50	47.75	49.50	47.13	49.25	48.50	50.00	53.88
46	46.50	47.88	47.00	47.75	50.00	48.19	49.38	49.00	49.75	52.00	49.44	51.88	50.75	52.25	56.50
48	48.50	49.75	49.00	50.00	52.00	50.00	51.63	51.00	52.00	54.00	51.44	53.88	53.00	54.75	58.50
50	50.50	51.88	51.00	52.00	-	52.19	53.38	53.00	54.00	-	53.44	55.88	55.25	57.00	-
52	52.50	53.88	53.00	54.00	-	54.19	55.38	55.00	56.00	-	55.44	57.88	57.25	59.00	-
54	54.50	55.25	55.25	56.25	-	56.00	57.25	57.25	58.25	-	57.63	60.25	59.75	61.25	-
56	56.88	58.25	57.25	58.25	-	58.19	60.00	59.25	60.25	-	59.63	62.75	61.75	63.50	-
58	59.08	60.44	59.25	60.50	-	60.19	61.94	61.25	62.50	-	62.19	65.19	63.75	65.50	-
60	61.31	62.56	61.75	62.75	-	62.44	64.19	63.75	64.75	-	64.19	67.19	66.25	68.25	-

*Despite careful content control we assume no liability or guarantee for the topicality, correctness and completeness of the information provided

Chemical resistance guide

Comparison of media resistance of most common gasket sealing materials mentioned in this brochure.

There are four different cases:

- A** 1. Suitable
- B** 2. Depends on conditions
- C** 3. Not suitable
- 4. No data available

In case of resistance result is B, resistance depending on operating conditions, consult the engineers of Leader Gasket.

The following media resistance list should give an overview. For media that are not included in this list, you are advised to contact the engineering team of the Leader group.

	Graphite Foil	SS316	PTFE	Leader THERM	Clipperlon 2100	Clipperlon 2110	Clipperlon 2120	Clipperlon ePTFE*
Acetaldehyde	-	-	-	B	A	A	A	A
Acetamide	A	A	A	B	A	A	A	A
Acetic Acid	-	-	-	A	A	A	A	A
Acetic Acid Glacial	-	-	-	A	A	A	A	A
Acetic Anhydride	-	-	-	-	A	A	A	A
Acetone	A	-	A	B	A	A	A	A
Acetonitrile	-	-	-	-	A	A	A	A
Acetyl Chloride	-	-	-	-	A	A	A	A
Acetylene	A	A	A	B	A	A	A	A
Acrylic Acid	A	A	A	-	A	A	A	A
Acrylonitrile	A	A	A	-	A	A	A	A
Adipic Acid	A	A	A	A	A	A	A	A
Air	-	-	-	A	A	A	A	A
Allyl Chloride	-	-	-	-	A	A	A	A
Alum	A	B	A	A	A	A	A	A
Aluminium Acetate	A	A	A	A	A	A	A	A
Aluminium chlorate	A	A	A	A	-	-	-	-
Aluminium Chloride	A	C	A	A	A	A	A	A
Aluminium Hydroxide	-	-	-	-	A	A	A	A
Aluminium Sulphate	A	B	A	-	A	A	A	A
Aluminum fluoride	A	C	A	-	-	-	-	-
Ammonia	A	A	A	A	-	-	-	-
Ammonia Gas	A	A	A	A	A	A	A	A
Ammonium bifluoride	A	A	A	-	-	-	-	-
Ammonium Carbonate	A	A	A	A	A	A	A	A
Ammonium Chloride	A	B	A	A	A	A	A	A
Ammonium diphosphate	A	A	A	A	-	-	-	-
Ammonium fluoride	A	A	A	-	-	-	-	-
Ammonium Hydroxide	A	A	A	A	A	A	A	A
Ammonium Sulphate	-	-	-	-	A	A	A	A
Amyl Acetate	A	A	A	A	A	A	A	A
Amyl Alcohol	A	A	A	-	A	A	A	A
Aniline (aminobenzene)	A	A	A	B	A	A	A	A
Aqua Regia	C	C	A	-	A	A	A	A
Arcton 12	-	-	-	C	-	-	-	-
Arcton 22	-	-	-	C	-	-	-	-
Asphalt	-	-	-	A	A	A	A	A
Aviation Fuel	-	-	-	-	A	A	A	A
Barium Chloride	A	A	A	A	A	A	A	A
Barium salt, aqueous	A	A	A	-	-	-	-	-
Benzaldehyde	-	-	-	-	A	A	A	A
Benzene	A	A	A	B	A	A	A	A
Benzoic Acid	A	A	A	A	A	A	A	A
Benzonitrile	-	-	-	-	A	A	A	A
Benzyl Alcohol	-	-	-	-	A	A	A	A

*Clipperlon ePTFE styles 2130/2135/600/660

	Graphite Foil	SS316	PTFE	Leader THERM	Clipperlon 2100	Clipperlon 2110	Clipperlon 2120	Clipperlon ePTFE*
Benzyl Chloride	A	A	B	-	A	A	A	A
Black liquor (sulfate)	A	-	A	-	-	-	-	-
Black liquor (sulfide)	A	-	A	-	-	-	-	-
Blast Furnace Gas	-	-	-	A	A	A	A	A
Bleach (solution)	A	B	A	A	A	A	A	A
Boiler Feed Water	-	-	-	-	A	A	A	A
Borax	A	A	A	A	A	A	A	A
Boric Acid	A	A	A	A	A	A	A	A
Brine	-	-	-	-	A	A	A	A
Bromine	C	C	A	-	A	A	A	A
Bromine trifluoride	C	C	C	-	-	-	-	-
Butadiene	A	A	A	-	A	A	A	A
Butane	A	A	B	-	A	A	A	A
Butanol	A	A	A	B	A	A	A	A
Butanone (methyl ethyl ketone)	A	A	A	B	-	-	-	-
Butyl Acetate	A	A	A	B	A	A	A	A
Butyl Alcohol	-	-	-	B	A	A	A	A
Butyl amine	A	A	A	B	-	-	-	-
Butyl Methacrylate	-	-	-	-	A	A	A	A
Butylphenol	A	A	A	-	-	-	-	-
Butyric Acid	A	A	A	B	A	A	A	A
Calcium Chloride	A	B	A	A	A	A	A	A
Calcium Hydroxide	A	A	A	A	A	A	A	A
Calcium Hypochlorite	A	B	A	A	A	A	A	A
Calcium oxide	A	A	A	-	-	-	-	-
Calcium Sulphate	A	A	A	A	A	A	A	A
Carbamide (urea)	A	A	A	-	-	-	-	-
Carbolic Acid	A	A	A	-	A	A	A	A
Carbon Dioxide	A	A	A	A	A	A	A	A
Carbon Disulphide	A	A	A	B	A	A	A	A
Carbon hydride	A	A	A	-	-	-	-	-
Carbon Monoxide	-	-	-	-	A	A	A	A
Carbon Tetrachloride	A	A	A	B	A	A	A	A
Castor Oil	-	-	-	A	A	A	A	A
Caustic potash solution, liquid	A	A	A	-	-	-	-	-
Caustic Soda < 25%	A	C	A	-	C	B	A	A
Caustic Soda < 50%	A	C	A	-	C	B	A	A
Caustic Soda > 50%	A	C	A	-	C	B	A	A
Cesium melt	-	-	C	-	-	-	-	-
Chlorine (Dry)	A	A	A	B	A	A	A	A
Chlorine (Wet)	C	C	A	-	A	A	A	A
Chlorine bleach liquor	A	C	A	-	-	-	-	-
Chlorine Dioxide	C	C	A	-	A	A	A	A
Chlorine Liquid	C	C	A	-	A	A	A	A
Chlorine trifluoride	C	C	C	-	-	-	-	-
Chloroacetic Acid	A	C	A	-	A	A	A	A
Chlorobezene	A	A	A	-	A	A	A	A
Chloroform	A	A	A	B	A	A	A	A
Chloromethane (methyl chloride)	A	A	A	B	-	-	-	-
Chlorotrifluoride	-	-	-	-	C	C	C	C
Chromic Acid	A	A	A	B	A	A	A	A
Chroming solutions	B	B	-	-	-	-	-	-
Citric Acid	-	-	-	A	A	A	A	A
Condensation Water	-	-	-	A	A	A	A	A
Copper Acetate	A	A	A	A	A	A	A	A
Copper Sulphate	A	A	A	A	A	A	A	A
Creosote	-	-	-	-	A	A	A	A
Cresol	A	A	A	A	A	A	A	A
Crude Oil	-	-	-	A	A	A	A	A
Cyclohexane	A	A	A	-	A	A	A	A
Cyclohexanol	A	A	A	A	A	A	A	A
Cyclohexanone	A	A	A	B	A	A	A	A
Decalin (decahydronaphthalene)	A	A	A	A	-	-	-	-
Di-Benzyl Ether	A	A	A	B	A	A	A	A
Dibutyl Phthalate	A	A	A	A	A	A	A	A
Diesel Oil	A	A	A	-	A	A	A	A

*Clipperlon ePTFE styles 2130/2135/600/660

	Graphite Foil	SS316	PTFE	Leader THERM	Clipperlon 2100	Clipperlon 2110	Clipperlon 2120	Clipperlon ePTFE*
Diethanolamine	-	-	-	-	A	A	A	A
Diethyl ketone (3-Pentanone)	A	A	A	-	-	-	-	-
Diethylamine	-	-	-	-	A	A	A	A
Di-iso Butyl Ketone	-	-	-	-	A	A	A	A
Dimethyl Formamide	A	A	A	-	A	A	A	A
Dimethylamine	A	A	A	-	A	A	A	A
Dioxane	A	A	A	-	A	A	A	A
Diphenyl (biphenyl)	A	A	A	-	-	-	-	-
Diphyl (Dowtherm A)	-	-	-	A B	A	A	A	A
Dithiophosphoric acid	A	-	A	-	-	-	-	-
Ethane	A	A	A	A	A	A	A	A
Ethanoic acid (pure acetic acid)	A	B	A	-	-	-	-	-
Ethanol	A	A	A	B	A	A	A	A
Ethyl Acetate	A	A	A	B	A	A	A	A
Ethyl Acrylate	-	-	-	-	A	A	A	A
Ethyl Alcohol	A	A	A	B	A	A	A	A
Ethyl Chloride (Dry)	A	A	A	B	A	A	A	A
Ethyl Ether	A	A	A	B	A	A	A	A
Ethylbenzene	-	-	-	-	A	A	A	A
Ethylene	A	A	A	B	A	A	A	A
Ethylene Chloride	A	A	A	B	A	A	A	A
Ethylene diamine	A	A	A	B	-	-	-	-
Ethylene Glycol	A	A	A	A	A	A	A	A
Ethylene oxide	A	A	C	-	-	-	-	-
Fatty acids	-	-	-	A	-	-	-	-
Fatty alcohols	A	A	A	-	-	-	-	-
Fluorine benzene	A	A	A	-	-	-	-	-
Fluorine Dioxide	C	C	C	-	C	C	C	C
Fluorine Gaseous	-	-	-	-	C	C	C	C
Fluorine hydrogen chloride	A	A	B	-	-	-	-	-
Fluorine Liquid	C	C	C	-	C	C	C	C
Fluorine, gaseous	B	C	C	-	-	-	-	-
Fluoroboric acid (borofluoric acid)	C	C	A	-	-	-	-	-
Fluorocarbon (hydrofluorocarbons)	A	A	A	-	-	-	-	-
Fluorosilicic acid (HF)	-	-	A	-	-	-	-	-
Fluosilic acid	A	-	A	-	-	-	-	-
Formaldehyde	A	A	A	B	A	A	A	A
Formamide	A	A	A	-	A	A	A	A
Formic Acid 10%	A	B	A	A	A	A	A	A
Formic Acid 85%	-	-	-	B	A	A	A	A
Freon 12	-	-	-	C	-	-	-	-
Freon 22	-	-	-	C	-	-	-	-
Fuel Oil	-	-	-	A	A	A	A	A
Gas (LPG)	-	-	-	-	A	A	A	A
Gas (Natural Gas)	-	-	-	-	A	A	A	A
Gas Oil	-	-	-	-	A	A	A	A
Gasoline	A	A	A	B	A	A	A	A
Generator Gas	-	-	-	-	A	A	A	A
Glucose	-	-	-	-	A	A	A	A
Glycerine	A	A	A	A	A	A	A	A
Gylcol	A	A	A	-	A	A	A	A
Heating Oil	-	-	-	B	A	A	A	A
Heptane	A	A	A	-	A	A	A	A
Hexachloro benzene	-	-	-	A	-	-	-	-
Hexamine (Urotropine)	A	-	-	-	-	-	-	-
Hexane	-	-	-	-	A	A	A	A
Hydraulic Oil	-	-	-	-	A	A	A	A
Hydraulic oil	A	A	A	A	-	-	-	-
Hydrazine	A	A	A	-	-	-	-	-
Hydrazine hydrate	A	A	A	A	-	-	-	-
Hydrochloric acid (aqueous)	A	C	A	A	-	-	-	-
Hydrochloric acid (dry)	A	C	A	A	-	-	-	-
Hydrochloric Acid 20%	A	C	A	A	A	A	A	A
Hydrochloric Acid 37%	A	C	A	A	A	A	A	A
Hydrocyanic acid	A	A	A	-	-	-	-	-
Hydrofluoric Acid <65%	A	C	A	-	C	C	A	A

*Clipperlon ePTFE styles 2130/2135/600/660

	Graphite Foil	SS316	PTFE	Leader THERM	Clipperlon 2100	Clipperlon 2110	Clipperlon 2120	Clipperlon ePTFE*
Hydrofluoric Acid >65%	-	-	-	-	C	C	B	A
Hydrofluorosilicic Acid	-	A	A	-	C	C	B	B
Hydrogen	-	-	-	A	A	A	A	A
Hydrogen Chloride (Dry)	A	C	A	-	A	A	A	A
Hydrogen Flouride	A	C	A	B	C	C	C	A
Hydrogen Peroxide (6%)	B	A	A	A	A	A	A	A
Hydrogen Sulphide	A	B	A	-	A	A	A	A
Hydrosilicic fluorid acid	A	-	A	-	-	-	-	-
Hydrosilico fluoride	A	-	A	-	-	-	-	-
Iodine	A	A	A	-	-	-	-	-
Isoctane	A	A	A	A	A	A	A	A
Isopropyl Acetate	-	-	-	-	A	A	A	A
Isopropyl Alcohol	A	A	A	B	A	A	A	A
Isopropyl Ether	-	-	-	-	A	A	A	A
Kerosene	A	A	A	A	A	A	A	A
Kerosine	A	A	A	-	-	-	-	-
Ketone	A	A	A	-	-	-	-	-
Lactic Acid	A	B	A	A	A	A	A	A
Lauryl alcohol	A	A	A	-	-	-	-	-
Lead acetate	A	A	A	A	-	-	-	-
Lead arsenate	A	A	A	A	-	-	-	-
Lime water	A	A	A	-	-	-	-	-
Linseed Oil	-	-	-	A	A	A	A	A
Liquid Petroleum Gas	-	-	-	-	A	A	A	A
Lithium bromide	A	A	A	-	-	-	-	-
Lithium melt	-	-	C	-	-	-	-	-
Lubricating Oil	-	-	-	-	A	A	A	A
Luminescent gas	-	-	-	B	-	-	-	-
Machine Oil	-	-	-	-	A	A	A	A
Magnesium hydroxide	A	A	A	-	-	-	-	-
Magnesium Sulphate	A	A	A	A	A	A	A	A
Maleic Acid	A	A	A	A	A	A	A	A
Maleic Anhydride	A	A	A	-	A	A	A	A
Methane	A	A	A	B	A	A	A	A
Methanol	A	A	A	B	A	A	A	A
Methyl Alcohol	A	A	A	B	A	A	A	A
Methyl Chloride	-	-	-	B	A	A	A	A
Methyl Ethyl Ketone	-	-	-	B	A	A	A	A
Methyl Methacrylate	-	-	-	-	A	A	A	A
Methylated Spirits	-	-	-	-	A	A	A	A
Methylene Chloride	A	B	B	B	A	A	A	A
Mineral Oil	-	-	-	A	A	A	A	A
Mobiltherm 600	-	-	-	-	A	A	A	A
Mobiltherm 603/605	-	-	-	-	A	A	A	A
Molten Alkali Metals	-	-	-	-	C	C	C	C
Morpholine	A	-	A	-	-	-	-	-
Motor Oil	-	-	-	-	A	A	A	A
Naphtha	A	-	A	-	A	A	A	A
Naphthalene	A	-	A	-	A	A	A	A
Natural Gas	A	A	A	B	A	A	A	A
Nickel Chloride	-	-	-	-	A	A	A	A
Nickel Sulphate	-	-	-	-	A	A	A	A
Nitric Acid < 30%	B	C	A	A	A	A	A	A
Nitric Acid > 30%	B	C	A	A	A	A	A	A
Nitric Acid Red Fuming	-	-	-	-	A	A	A	A
Nitrobenzene	A	A	A	A	-	-	-	-
Nitrogen	-	-	-	A	A	A	A	A
Octane	A	A	A	A	A	A	A	A
Oil	A	A	A	-	-	-	-	-
Oleic Acid	A	A	A	A	A	A	A	A
Oleum	C	C	A	A	A	A	C	A
Oxalic Acid	A	C	A	A	A	A	A	A
Oxygen	A	A	A	A	A	C	A	A
Paint thinner	-	-	-	A	-	-	-	-
Palmitic Acid	A	A	A	A	A	A	A	A
Paraffin	-	-	-	-	A	A	A	A

*Clipperlon ePTFE styles 2130/2135/600/660

	Graphite Foil	SS316	PTFE	Leader THERM	Clipperlon 2100	Clipperlon 2110	Clipperlon 2120	Clipperlon ePTFE*
p-dihydroxybenzene	A	-	A	-	-	-	-	-
Pentane	A	A	A	A	A	A	A	A
Perchloric Acid	B	C	A	-	A	A	A	A
Perchloro ethylene	A	A	A	B	A	A	A	A
Petrol ether	-	-	-	B	-	-	-	-
Petroleum	A	A	A	A	A	A	A	A
Phenol	A	A	A	A	A	A	A	A
Phosgene	A	A	A	-	A	A	A	A
Phosphoric Acid < 45%	A	A	A	A	A	A	A	A
Phosphoric Acid > 45%	A	B	A	A	B	B	A	A
Phosphoric acid, impure	A	B	A	-	-	-	-	-
Phthalic Acid	A	A	A	A	A	A	A	A
Phthalic Anhydride	-	-	-	-	A	A	A	A
Polychlorinated biphenyl (Clophen)	A	A	A	-	-	-	-	-
Potassium Acetate	A	A	A	A	A	A	A	A
Potassium bifluorine, saturated	A	A	A	-	-	-	-	-
Potassium Carbonate	A	A	A	A	A	A	A	A
Potassium Chlorate	C	A	A	A	A	A	A	A
Potassium Chloride	A	A	A	A	A	A	A	A
Potassium chromate	B	C	A	-	-	-	-	-
Potassium chrome sulfate	-	C	A	A	-	-	-	-
Potassium Cyanide	A	A	A	A	A	A	A	A
Potassium Dichromate <20%	-	-	-	A	A	A	A	A
Potassium Hydroxide < 50%	A	A	A	A	C	C	A	A
Potassium Hydroxide >50%	A	A	A	A	C	C	A	A
Potassium Hypochlorite	A	C	A	A	A	A	A	A
Potassium iodide	A	A	A	A	-	-	-	-
Potassium melt up to 350 °C	A	-	C	-	-	-	-	-
Potassium Nitrate	C	C	A	A	A	A	A	A
Potassium nitrate (melt)	C	C	C	-	-	-	-	-
Potassium Permanganate	A	A	A	A	A	A	A	A
Potassium silicate	A	A	A	-	-	-	-	-
Producer Gas	-	-	-	-	A	A	A	A
Propane	A	A	A	A	A	A	A	A
Pyridine	A	A	A	B	A	A	A	A
Rape Seed Oil	-	-	-	A	A	A	A	A
Refrigerant R11	-	-	-	-	A	A	A	A
Refrigerant R112	-	-	-	-	A	A	A	A
Refrigerant R113	-	-	-	-	A	A	A	A
Refrigerant R114	-	-	-	-	A	A	A	A
Refrigerant R114B2	-	-	-	-	A	A	A	A
Refrigerant R115	-	-	-	-	A	A	A	A
Refrigerant R12	-	-	-	-	A	A	A	A
Refrigerant R123	-	-	-	-	A	A	A	A
Refrigerant R125	-	-	-	-	A	A	A	A
Refrigerant R13	-	-	-	-	A	A	A	A
Refrigerant R134A	-	-	-	-	A	A	A	A
Refrigerant R13B1	-	-	-	-	A	A	A	A
Refrigerant R141A	-	-	-	-	A	A	A	A
Refrigerant R141B	-	-	-	-	A	A	A	A
Refrigerant R152A	-	-	-	-	A	A	A	A
Refrigerant R22	-	-	-	-	A	A	A	A
Refrigerant R402A	-	-	-	-	A	A	A	A
Refrigerant R402B	-	-	-	-	A	A	A	A
Refrigerant R404A	-	-	-	-	A	A	A	A
Refrigerant R502	-	-	-	-	A	A	A	A
Refrigerant R507	-	-	-	-	A	A	A	A
Salicylic Acid	-	-	-	-	A	A	A	A
Salicylic acid	A	A	A	A	-	-	-	-
Santotherm 66	-	-	-	-	A	A	A	A
Sea Water	-	-	-	A	A	A	A	A
Silicone Oil	-	-	-	A	A	A	A	A
Silver Nitrate	-	-	-	-	A	A	A	A
Skydrol 500	-	-	-	A	-	-	-	-
Soap	-	-	-	A	A	A	A	A
Soda	A	A	A	-	-	-	-	-

*Clipperlon ePTFE styles 2130/2135/600/660

	Graphite Foil	SS316	PTFE	Leader THERM	Clipperlon 2100	Clipperlon 2110	Clipperlon 2120	Clipperlon ePTFE*
Sodium acetate	A	A	A	-	-	-	-	-
Sodium Aluminate	A	-	A	A	A	A	A	A
Sodium ammonium hydrogen phosphate	A	A	A	-	-	-	-	-
Sodium Bicarbonate	A	A	A	A	A	A	A	A
Sodium Bisulphite	A	A	A	A	A	A	A	A
Sodium carbonate	A	A	A	A	-	-	-	-
Sodium Chloride	A	B	A	A	A	A	A	A
Sodium cyanide	A	A	A	A	-	-	-	-
Sodium hexafluoroaluminate / cryolite	A	-	A	-	-	-	-	-
Sodium Hydroxide < 25%	A	C	A	A	C	B	A	A
Sodium Hydroxide < 50%	A	C	A	A	C	B	A	A
Sodium Hydroxide > 50%	A	C	A	A	C	B	A	A
Sodium hypochlorite	A	C	A	-	-	-	-	-
Sodium melt up to 350 °C	A	-	C	-	-	-	-	-
Sodium phosphate, bibasic	A	A	A	-	-	-	-	-
Sodium phosphate, tribasic	A	A	A	-	-	-	-	-
Sodium Silicate	A	A	A	A	A	A	A	A
Sodium Sulphate	A	A	A	A	A	A	A	A
Sodium Sulphide	A	B	A	A	A	A	A	A
Starch	-	-	-	A	A	A	A	A
Steam	-	-	-	A	A	A	A	A
Stearic Acid	A	A	A	A	A	A	A	A
Styrene	A	A	C	-	A	A	A	A
Sugar	-	-	-	A	A	A	A	A
Sulphur	-	-	-	-	A	A	A	A
Sulphur Dioxide Dry	A	A	A	A	A	A	A	A
Sulphur Trioxide	C	C	A	-	A	A	A	A
Sulphuric Acid 30%	A	C	A	C	A	A	A	A
Sulphuric Acid 50%	A	C	A	C	A	A	A	A
Sulphuric Acid 96%	A	C	A	C	A	A	B	A
Sulphuric Acid Fuming	C	C	A	-	A	B	C	A
Sulphurous Acid	A	B	A	A	A	A	A	A
Tannic Acid	A	A	A	A	A	A	A	A
Tannin	A	A	A	-	-	-	-	-
Tar	-	-	-	A	A	A	A	A
Tartaric Acid	-	-	-	A	A	A	A	A
Tetrachloro ethane	A	A	A	B	A	A	A	A
Tetrafluor boric acid (HF)	A	C	A	-	-	-	-	-
Tetraline	A	A	A	A	-	-	-	-
Thermal Oil	-	-	-	-	A	A	A	A
Toluene	A	A	A	A	A	A	A	A
Transformer Oil	-	-	-	A	A	A	A	A
Transmission Oil	-	-	-	-	A	A	A	A
Tricalcium phosphate	A	A	A	-	-	-	-	-
Trichlorethylene	A	A	A	B	A	A	A	A
Trichlorotrifluoroethane (F113)	A	A	B	-	-	-	-	-
Triethanolamine	A	-	A	A	A	A	A	A
Triethylene aluminium	A	-	C	-	-	-	-	-
Triethylenetetramine	A	-	A	-	-	-	-	-
Trisodium phosphate	A	A	A	-	-	-	-	-
Turpentine	A	A	A	A	A	A	A	A
Urea	-	-	-	A	A	A	A	A
Vegetable Oil	-	-	-	-	A	A	A	A
Vinyl Acetate	-	-	-	A	A	A	A	A
Vinyl Bromide	-	-	-	-	A	A	A	A
Vinyl Chloride	A	-	A	-	A	A	A	A
Water	-	-	-	A	A	A	A	A
White Spirit	-	-	-	-	A	A	A	A
Xylene	-	-	-	A	A	A	A	A
Zinc Chloride	-	-	-	-	A	A	A	A
Zinc Sulphate	-	-	-	-	A	A	A	A

*Clipperlon ePTFE styles 2130/2135/600/660

The above information in this document corresponds to the current state of our knowledge and is intended to inform about our products and their potential applications. It is therefore not intended to assure certain properties for a specific purpose. Any existing industrial property rights are to be taken into account. We guarantee perfect quality within the framework of our general terms and conditions of sale“.

Profile overview

LEADER SPIRAL WOUND GASKETS		
Drawing	Style	Description
	S	without inner or outer ring
	SR	with outer ring
	SI	with inner ring
	SRI	with inner or outer ring

LEADERKAM KAMMPROFILE GASKET		
Drawing	Style	Description
	F	without centering rim
	FR	with machined integral centering ring
	FL	with loose centering ring

LEADER CORRUGATED GASKET		
Drawing	Style	Description
	Elastagraph	Pipe Flange Gasket
	Elastagraph SG	Pipe Flange Special or Equipment Gasket

LEADER RTJ GASKETS		
Drawing	Style	Description
	OV	Oval
	OC	Octagonal
	RX	RX
	BX	BX

Metal Jacketed Gaskets

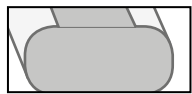

Style 20

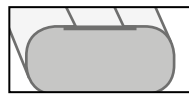

Style 23



Style 24

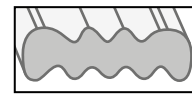

Style 26



Style 27

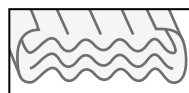

Style 29

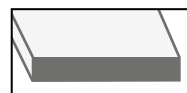

Style 40

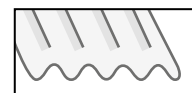

Style 00

Style 20 The single jacketed gasket is most commonly used when a narrow width gasket cross section is required. They are made by encasing a soft filler with a single piece of metal. This design provides for the protection of both edges of the soft gasket material. Most single jackets are made of copper and have cross sections less than 6 mm. For cross sections greater than 6 mm, double jacketed gaskets are recommended.

Style 23 This gasket is a double jacketed profile made from two pieces of metal and a soft filler. It is the most commonly used profile for heat exchangers and other vessels. The Style-23 has greater compressibility and resilience than a solid metal gasket due to the enclosure of the soft filler. The two piece metal construction also provides extra rigidity allowing for large diameters.

Style 24 This gasket is similar to the Style -20, however the single piece of metal is shaped such as to provide for the complete enclosure of the soft filler.

Style 26 This gasket is formed with two pieces of corrugated metal enclosing a soft filler.

Style 27 This gasket is a double shell gasket made with two reversed wrap around metal shells encasing a soft filler material.

Style 29 This gasket has a two piece corrugated metal jacket enclosed over a corrugated metal filler rather than a soft filler material.

Style 40 This gasket is a solid piece of metal which is similar to a kammprofile gasket without the grooves. It can be ordered with flexible graphite or PTFE applied to both faces

Style 00 is a corrugated metal gasket uncovered which provides some resilience and multiple sealing points.

Fixed Equipment Shapes

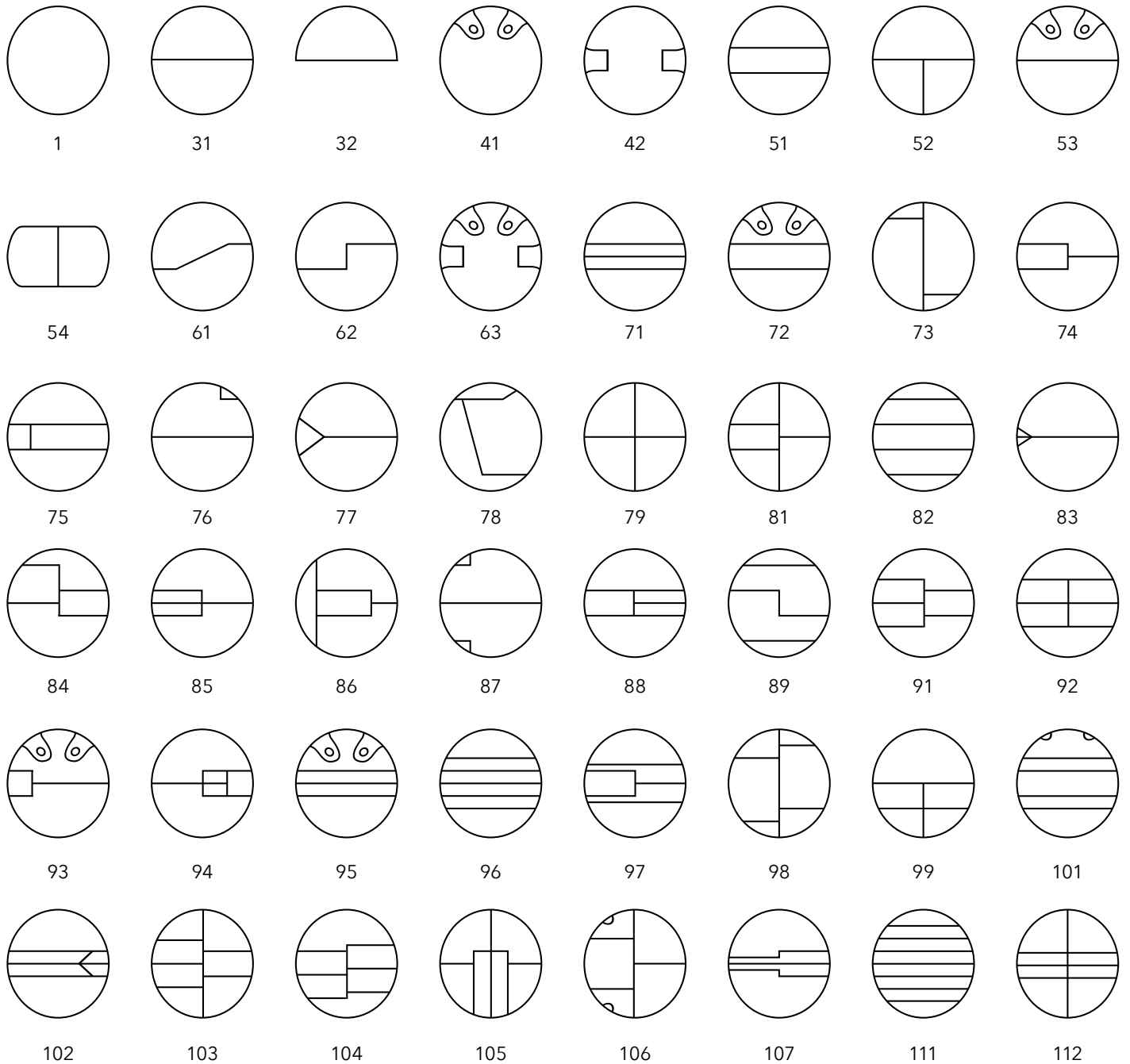



Leader Gasket warrants that its products are manufactured in accordance with its applicable material specifications and are free from defects in materials and workmanship using Leader Gasket' specifications as a standard. Only products which are installed and used in accordance with applicable Leader Gasket instructions and specifications are in any way warranted by Leader Gasket. This warranty is applicable only to claims made in writing and reviewed by Leader Gasket within 30 days after the defect was discovered or should have been discovered and within one year after the date of shipment of the product by Leader Gasket. All other claims are waived. If a claim is made, you must allow reasonable investigation of the product you claim is defective and you must supply samples that adequately demonstrate the problem you claim for testing by Leader Gasket.

Leader Gasket makes no other representation or warranty of any kinds, express or implied, in fact or in law, including without limitation, length of service life, merchantability, or the fitness for a particular purpose, other than the limited warranty set forth above. The limited warranty provides your exclusive remedy as a modified or amended only by a written instrument signed by a duly authorized representative of Leader Gasket. Without an express written authorization from Leader Gasket, no retailer or distributor of Leader Gasket has the authority to modify or amend the limited warranty.





Global Headquarters Deer Park, TX

850 Sens Road La Porte, TX 77536 | Ph: 281. 542.0600 | Fx: 281. 542.5552
info@leadergt.com

Baton Rouge, LA

10609 North Dual Dr. Baton Rouge, LA 70814 Ph: 225.275. 8000 | Fx: 225.273.9073
info@leadergt.com

European Headquarters Slovakia

Psrnovicka Ulica 1026, 014 01 Bytca, Republic of Slovakia | Ph: +421.41. 5532686 | Fx: +421.41. 5532895
infoEurope@leadergt.com

For more information on our locations or our distributor network, please visit www.leadergt.com or send us an email

